



Federal Pacific Continues to Lead the Way in Pad-Mounted Automatic Source-Transfer Switchgear, Featuring the SEL-451 Relay



Figure 1 – Exterior view of a typical four-compartment Federal Pacific ATPSE-9-44222 15kV Automatic Source-Transfer Pad-Mounted Dead-Front Switchgear. The “9” configuration, as shown in this illustration, configured with two three-phase source switches and two three-phase sets of load fuses, is the most common configuration for Pad-Mounted Automatic Source-Transfer Switchgear.

In late 2011, Federal Pacific introduced the Schweitzer Electronic Laboratories (SEL) 451 relay in automatic transfer switchgear. Over the past two years, this transition to the SEL-451 relay has proven to be very successful for Federal Pacific, most particularly with utilities whose substation groups are well aware of the quality and versatility inherent in SEL products and, perhaps more importantly, SEL’s uncompromising customer support, highlighted by a ten-year warranty. For those “in the know”, the SEL-451 relay is a product enhancement that sells itself.

Figures 1 – 3 show the overall configuration of the most common type of Dead-Front Automatic Source-Transfer Pad-Mounted Switchgear, the ATPSE-9. This particular switchgear unit, intended for a major utility in the Midwest, is the Federal Pacific ATPSE-9-44222 15kV Automatic Source-Transfer Pad-Mounted Dead-Front Switchgear. The “9” configuration, as shown in these illustrations, with two three-phase gang-operated source switches and two three-phase sets of load fuses, is the most common configuration for Pad-Mounted Automatic Source-Transfer Switchgear.



Figure 2 – In this view, the doors of the low-voltage cabinets are open, showing the standard run-and-trip motor operator in the cabinet to the left, and the control cabinet, featuring the SEL-451 relay, in the cabinet to the right. The control cabinet is shown in detail in Figure 6.

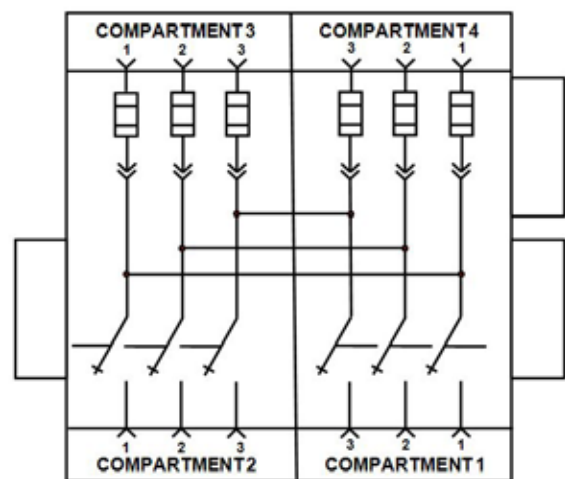

Figure 3 – Circuit Diagram for typical ATPSE-9 Dead-Front Pad-Mounted Switchgear, with three-phase Auto-jet® switches in compartments 1 and 2, and a three-phase set of fuses in compartments 3 and 4.

When combined with Federal Pacific's industry-leading switchgear design, customer focused service, flexibility of design to accommodate customer requested features, and the industry's best of class lead time, this one-two combination is a proven winner, gaining ever wider usage in the medium voltage switchgear market.

There are, however, untapped markets which may not have been aware of the reasons to consider automatic transfer in general, and the advantages of selecting Federal Pacific in particular.

Power Quality and the Need for Premium Service in Some Cases

Expectations for power quality and availability have increased in recent years, especially in the case of critical infrastructure customers and facilities, such as the medical, security, transportation, and energy sectors. Utilities and other energy providers are evaluated for both their reliability and their availability.

Over the past several years, utilities and other power providers have placed increasing emphasis on reliability, from the system level, down to the component level, realizing that reliability, like quality, is an intrinsic value which must be pursued through incorporation at the design level. As system reliability and power plant availabilities have improved, the impact of the outlying events, beyond the control of the utilities, such as a vehicle striking a pole, a cable dig-in, or abnormally severe weather events have become more obvious, especially for the critical or high profile customers. In these cases, a redundant method of service is essential.

Modern underground systems typically provide a manual level of redundancy through the use of open loops, both at the distribution feeder level from the substation, as well as at the fused loop level, providing service to the distribution transformers or, for large loads, direct primary feeds. By means of these looped systems, underground service can typically be restored as quickly as, or more quickly than, the overhead system, by means of temporarily switching to isolate damaged or failed equipment or cable systems in order to restore service to the unaffected sections. This allows the underground construction crews to be dispatched more efficiently to affect a permanent repair. This two-step process, "switch, then fix", allows rapid deployment to restore service quickly to the majority of customers, allowing the repair crews to be dispatched later in a more cost effective manner. Most of the time, this is enough, especially for typical residential loads.

This system, although good enough in the majority of cases, has its limitations, especially in the case of the critical infrastructure or high profile customers. For these "critical customers", the time required to dispatch switching personnel to the field and to execute the switching order, typically 30 minutes to an hour or more, may be unacceptable. These are typically large customers or governmental agencies with political influence, resources, "high profiles", and the means to

seek alternative energy sources, should their electrical supplier fall short of their needs or expectations. Hospitals, police and EMS stations, certain process production facilities, sewer treatment plants, and sporting venues are some typical examples of these large and demanding customers.

At the same time, such apparent adversity may be opportunity by another name. The electrical suppliers with a quality power source and redundant feeds can better serve these "critical customer" loads than an upstart energy provider. The key is to understand the customer's needs and to support them in such a way as to become the preferred power supplier, largely (if not totally), to the exclusion of the competition.

Those who understand the customer's needs and to have the resources, equipment, and willingness to meet those needs are in the position to drive these key markets in their direction. Federal Pacific can supply the equipment needed.

Why Automatic Source-Transfer Switchgear?

Various methods to provide greater availability critical loads have been used over the years, such as secondary "street network" systems covering significant areas used in some urban areas, vault level secondary networks for specific customers, and large-scale UPS systems for point applications. Each of these systems provides markedly better reliability. They also share some negative features – they tend to be expensive to install, high-maintenance systems, which must be tended by specialized engineering and operational personnel.

Federal Pacific automatic source-transfer systems provide an economical alternative to expensive, capital-intensive, network systems or maintenance intensive battery-based back-up systems, by restoring power in a matter of seconds, as opposed to the typical 30 to 60 minute response times (and sometimes even more) when field personnel must be dispatched to remote switching locations or navigate through heavy urban traffic.

Federal Pacific Automatic Source Transfer Switchgear provides automatic two-way source transfer with the ability to connect either the two utility sources, or a utility source and a standby generator, to the switchgear bus. In automatic transfer switchgear, one incoming line switch is normally closed (typically the preferred utility source) and the other incoming line is normally open (alternate source or generator).

The Federal Pacific automatic control, featuring the SEL-451 relay, monitors the condition of both power sources and initiates automatic switching when the preferred-source voltage drops below a preset level for a selected length of time (field selectable) that is sufficient to determine that the voltage drop is not caused by a transient condition. When these two conditions (sufficient voltage drop for a sufficient period

of time) are met on the Preferred source are then a transfer to the Alternate source is initiated.

The transfer from the "Preferred" source to the "Alternate" source is accomplished by means of an "Open Transfer" where the two sources are not connected in parallel. In an Open Transfer, the Preferred source switch will open first, and then the Alternate source switch will close to pick up the load. This is done to eliminate the possibility of the automatic-transfer switchgear connecting the Alternate source to a potential source side fault on the Preferred source through the switchgear.

Once the Preferred source has shown proper voltage for a determined period of time, the switchgear transfers back from the Alternate source to the Preferred source. Normally, this is a "Closed Transfer", with the Alternate source switch closing before the Preferred source switch opens, causing the two sources to be briefly tied together in order to avoid a "blink" on the customer's service. Some users prefer to use the Open Transfer to avoid tying the sources together. The choice is usually based on the user's system characteristics, history, and operating practices.

How Fast Does the Transfer Need to Be?

Probably the most controversial issue of automatic source-transfer is speed – how fast is fast enough? As one might expect, there is no single answer for all cases.

As with most engineering designs, there are trade-offs and value judgments which must be made. In a simplified two-dimensional model, the conflict is between speed and price. As one would expect, price tends to rise with the speed of transfer.

By building a looped system, as is the typical design for modern underground systems, the implication is that there is a value in providing a more reliable system with more rapid restoration than would be the case with a radial system, shortening the expected restoration time from hours to minutes. In considering automatic load transfer, the user has gone to the next level, shortening the restoration time yet again, now on the order of a few seconds or less.

Still, the questions comes back to how fast is fast enough?

For most residential and commercial loads, the 6 – 8 second transfer times of the standard run-and-trip motor operator, as shown in Figure 4, is fast enough. These transfer speeds will lead to a noticeable interruption (often called a "momentary"), but this brief interruption is well within the typical reclosing times of a station breaker or overhead recloser. Since most customers are served from feeders with reclosing sequences at the substation and/or a field recloser, standard run-and-trip transfer times should be more than sufficient.

At the other extreme, certain sensitive, high profile loads, such as high intensity discharge (HID) lighting (such as at sports fields, stadiums, and arenas) and some continuous process manufacturing operations, require transfer times on the order of one to two cycles (17 – 33 milliseconds). Neither the run-and-trip operator, nor the fast-trip operators, with transfer speeds on the order of 15 – 20 cycles after transfer initiation, are fast enough for these loads. It should also be noted that even designs from other manufacturers with speeds in the 8 – 10 cycle range (again after detection) are still not fast enough to maintain these sub-2-cycle loads.

There are also a middle range, high-profile critical loads where transfer times on the order of a quarter to half a second are adequate. Some examples might be hospitals, emergency response centers, many data processing centers, and most continuous process manufacturing operations. For this mid-range application, the fast-trip operator, as shown in Figure 5, should be sufficient. The customer would experience a short momentary interruption of well under a second, which would be similar to a delayed relay action of a station breaker or field recloser.

The point of this is that, for most applications, Federal Pacific's Automatic Source-Transfer is more than sufficient to meet the customers' valid requirements and provides a more cost-effective solution than many of the offerings from our competitors.

Once again, Federal Pacific Automatic Source-Transfer Switchgear provides the performance level need by our customers at competitive price-points, with the flexibility to meet specific design requirements, and a lead-time our competitors find hard to match.



Figure 4. The Federal Pacific Run-and-Trip motor operator, as illustrated above, provides automation for Federal Pacific Auto-jet® II load-interrupter switches. Federal Pacific motor operators have the reliability essential to providing power to critical loads. These motor operators include a decoupler to allow testing without affecting service continuity to the load; and a long-life battery and battery charger to insure functionality even when the control-power source is not available, which are just a few of the many important features furnished.



Figure 5. The Fast-Trip Motor Operator is illustrated above with the interlocked cover over the motor shown closed in the top photo above and with the cover open in the bottom photo above. As the motor rotates at high speed, if the cover is open motor operation is suspended. A separate key interlock (see arrow in photo) can be provided to block operation of the motor operator for other specific requirements, such as requiring that all switches be open before allowing access to fuses.

SEL-451 Relay, UPS, and Test Switches

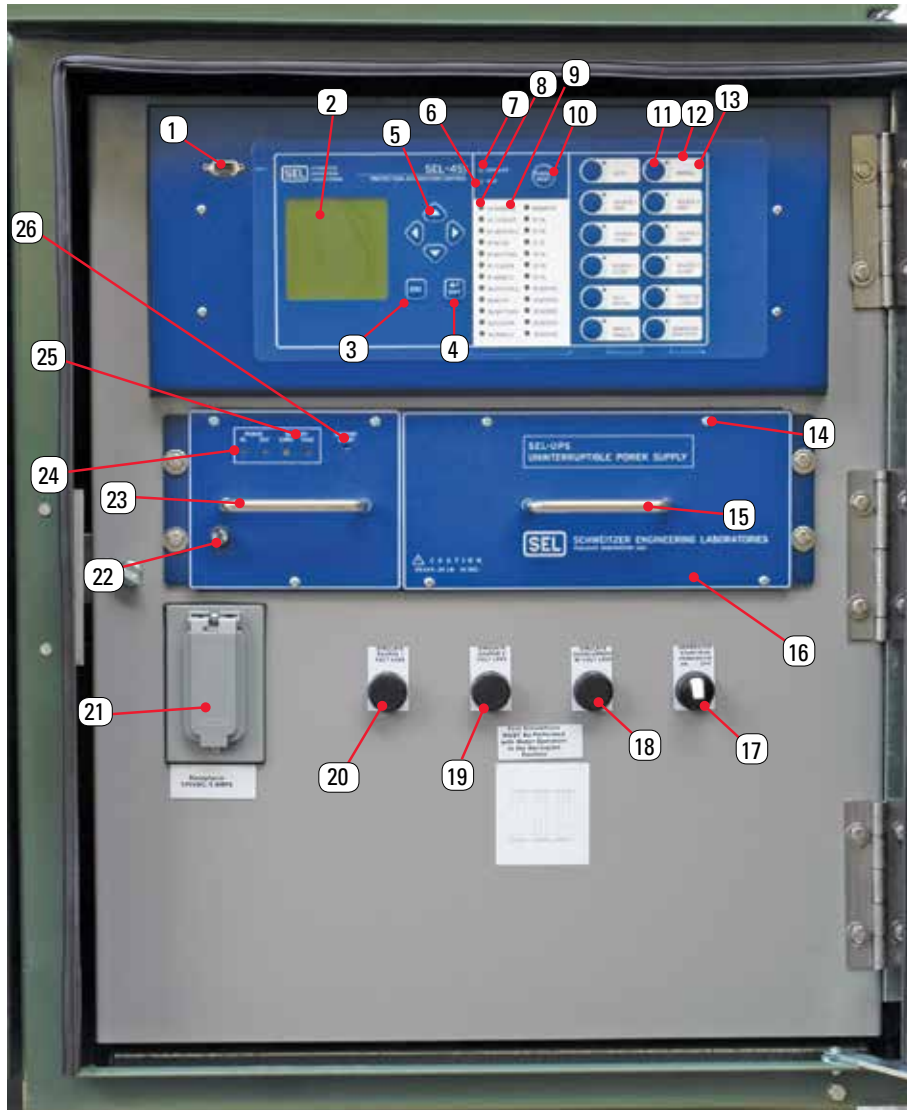

Figure 6. Faceplates and features of the SEL-451 relay and the UPS are illustrated above and each is identified by a numbered callout.

- | | |
|---|--|
| 1. Front Serial Port | 17. Test Switch - To Simulate Over-Current with Voltage Loss (i.e. Lockout Mode). |
| 2. LCD Screen | 18. Test Switch - To Simulate Source 2 Voltage Loss |
| 3. ESC – Escape Key | 19. Test Switch - To Simulate Source 1 Voltage Loss |
| 4. Enter Key | 20. Generator Start/Run Permissive On/Off Selector Switch |
| 5. Navigation Soft Keys for LCD Screen | 21. Duplex Receptacle Outlet - Allows connection of a laptop computer (5 amp fuse) |
| 6. Trip LED Indicating Lamp | 22. Fuse for Battery-Charger Circuit |
| 7. Enabled LED Indicating Lamp | 23. Battery-Charger Pullout Handle Grip |
| 8. Status Indicating Lamp (typical) | 24. Battery-Charger Power Status Indicating Lamps (IN and OUT) |
| 9. Status-Indicating-Lamp Functional Description (typical) | 25. Battery-Charging and Battery-Charger-Fuse Status Indicating Lamps |
| 10. Target Reset Soft Key | 26. Access Port to Activate UPS Battery to turn on Power to the Relay |
| 11. Actuation Soft Key to Change Status Condition (typical) | |
| 12. LED Indicating Lamp for Status Condition (typical) | |
| 13. Status Condition Label (typical) | |
| 14. Screws (4) Secure Battery in Position | |
| 15. Battery Pullout Handle Grip | |
| 16. Battery Compartment | |

(Previously shown in December 2011 Newsletter)

Auxiliary Components & Capabilities

The Federal Pacific automatic-transfer scheme includes a UPS (uninterruptable power supply), test function capabilities and an electrical outlet. The SEL-UPS provides adequate battery backup for the SEL-451 relay when control power has been lost regardless of cause. The UPS insures that the relay is always capable of performing its intended function whether or not the normal control-power source, the voltage transformers, is available. The UPS also includes a battery charger and associated alarm circuits (a) in the event AC Input to the battery charger is diminished or lost and (b) output from the battery is diminished below acceptable levels or lost.

The test function allows testing of the automatic-transfer scheme and of the over-current lockout system. These tests can be performed without actually opening and closing switches, which is made possible by the decoupling feature on the Federal Pacific motor operators. Pushbuttons are provided to allow (1) Simulating Loss of Voltage on Source 1, (2) Simulating Loss of Voltage on Source 2, and (3) Simulating an Overcurrent with a Loss of Source Voltage. These test functions exercise the automatic-transfer capability and when motors are coupled to switches will affect an actual transfer that will result in the loss of source voltage to the load or when the motors are decoupled from the associated switches will simulate a transfer that will not result in the loss of source voltage to the load.

The electrical outlet is provided to supply power for a laptop computer or other similar load. A duplex outlet is provided and the circuit is fused at 5 amperes. Consequently, the circuit is NOT adequate for power tools of any type.



Figure 7. The Federal Pacific automatic-transfer scheme includes a UPS (at top in photo), test pushbuttons to simulate loss of source voltage and over-current lockout to allow verification of the functionality of the transfer scheme, and a duplex outlet for connection of a laptop computer. Also see Figure 6.

(Previously shown in December 2011 Newsletter)

Interactive Soft Keys

A grouping of twelve (12) interactive soft keys combined with status LEDs and labels allow surface selection and actuation of a number of operating choices. See Figure 8.

The interactive soft keys that provide Local Operation capability on the faceplate of the SEL-451 relay include:

Open/Close keys for each source switch — Capability allows actual open and close operations of the associated switch and also illuminates an LED to display for each source the actual switch position (“Switch Open” — green or “Switch Closed” — red) of the associated switch.

Auto or Manual operation selection — establishes operating mode of the relay – actual mode is set by depressing the applicable soft key and status is indicated by illumination of the LED that is adjacent to the two soft keys labeled “Auto” and “Manual” in a green color, designating the present mode

Source 1 or Source 2 selected as the preferred source — capability for each source switch to provide service as the “Preferred” source, which provides power to the load under normal conditions, or as the “Alternate” source, which provides power to the load when the preferred source is not available.

Hold Return — Return to preferred source — if the “Auto Retransfer” MM Setting is disabled the return to the preferred source is blocked until the “Hold Return” soft key is pressed and held for three (3) seconds

Remote Enabled — capability for units furnished with SCADA interface to position the control in “Enabled” or “Disabled” mode. The control is by default in “Disabled” mode and can only be placed in “Enabled” mode through user positioning the interactive soft key on the faceplate of the relay as indicated by illumination of the associated LED

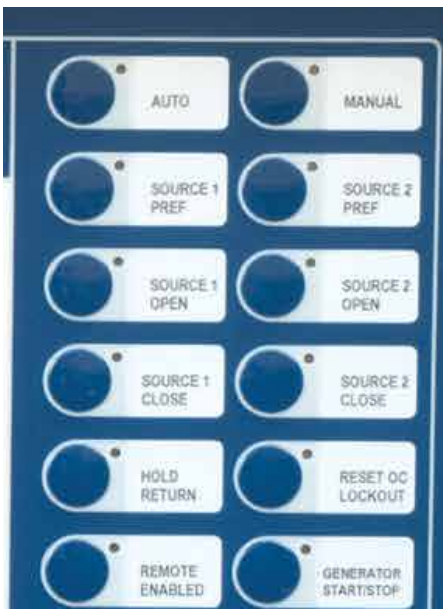

Figure 8. Twelve (12) interactive soft keys provide Local Operation capability on the faceplate of the SEL-451 relay. With Local Operation capabilities, operating personnel can perform switching operations and other key functions with direct interface on the relay.

Reset Over-Current Lockout — allows reset of the over-current lockout condition by touching the labeled soft key to reset the control following an over-current lockout condition. The associated LED is flashing red when an over-current lockout condition exists.

Generator Start/Stop — enabled if the alternate source is a generator

LCD Display

A large LCD display on the faceplate of the relay will continuously and automatically scroll through ten (10) primary display points. See Figure 9.

The primary display points include functions as follows:

Phase Currents for Source 1 and Source 2

Phase Voltages for Source 1 and Source 2

Mismatch for Motor 1 and Motor 2 — shows whether the motor and the switch are in the same position to permit coupling

UPS Battery Voltage — status of battery voltage (adequate or low)

Battery Charger — Status of AC input to the battery charger

Faulted Phase — Identification of the phase on which a fault has occurred

Permissive Generator Start — Status of start key if the alternate source is a generator

The LCD display also supports a Main Menu screen that allows access to:

EVENTS Log — provides date/time stamp on events and current/voltage at time of event

SET/SHOW — Function provides the facility to edit the DATE/TIME

DISPLAY TEST — Function provides the facility to perform a lamp test of all the LEDs to verify functionality of all LEDs



Figure 9. The LCD screen presents the continuously scrolling primary display points. In addition, soft keys facilitate navigation among the primary display points and the “Main Menu Screen”, which provides additional display points for the “EVENTS”, editing of the “DATE/TIME” and initiating the “DISPLAY TEST” to illuminate all LEDs to confirm that the lamps are functional.

(Previously shown in December 2011 Newsletter)

Functional Status LEDs

Additional functional status conditions for both sources are indicated by twenty-four (24) available illuminated LEDs with labels on the faceplate of the relay. See Figure 10.

These LEDs provide indications as follows:

Over-Current Suspend — Illuminates when an over-current has occurred and resets off if there is no loss of source voltage within the overcurrent-lockout timer setting

Over-Current Lockout — Illuminates when an over-current occurs that is followed by a loss-of-source voltage within the overcurrent-lockout timer setting

M1 Decouple — Motor 1 is decoupled — Capability displays for Motor 1 whether the mechanism is decoupled from the switch (LED illuminated) or coupled (LED not illuminated) to the associated switch

M1 No Go — LED is illuminated when Motor 1 has malfunctioned; otherwise LED is not illuminated

M1 Batt/Chg — Motor 1 Battery or Battery Charger has malfunctioned — LED is illuminated when Motor 1 battery or battery charger has malfunctioned; otherwise LED is not illuminated

M1 Cls/Opn — Motor 1 is Closed or Open — LED is illuminated green when Motor 1 is open; illuminated red when Motor 1 is closed

M1 Rem/Lcl — Motor 1 is in Remote or Local — LED is illuminated when Motor 1 is in remote; otherwise LED is not illuminated

M2 Decouple — Motor 2 is decoupled — Capability displays for Motor 2 whether the mechanism is decoupled from the switch (LED illuminated) or coupled (LED not illuminated) to the associated switch

M2 No Go — Motor 2 has malfunctioned — LED is illuminated when Motor 2 has malfunctioned; otherwise LED is not illuminated

M2 Batt/Chg — Motor 2 Battery or Battery Charger has malfunctioned — LED is illuminated when Motor 2 Battery or Battery Charger has malfunctioned; otherwise LED is not illuminated

M2 Cls/Opn — Motor 2 is Closed or Open — LED is illuminated green when Motor 2 is open; illuminated red when Motor 2 is closed

M2 Rem/Lcl — Motor 2 is in Remote or Local — LED is illuminated when Motor 2 is in remote; otherwise LED is not illuminated

Mismatch — Motor 1 and Source Switch 1 or Motor 2 and Source Switch 2 are not in the same positions — LED is illuminated when Motor 2 is in remote; otherwise LED is not illuminated

S1VA, S1VB and, S1VC — Illumination of the LED establishes for the applicable Source 1 phase whether the associated source voltage is available (above minimum conditions) or, if the LED is not illuminated, that source voltage is not available (below minimum conditions) on the associated phase

S2VA, S2VB and, S2VC — Illumination of the LED establishes for the applicable Source 2 phase whether the associated source voltage is available (above minimum conditions) or, if the LED is not illuminated, that source voltage is not available (below minimum conditions) on the associated phase



Figure 10. Twenty-four Status LEDs are provided to give actual status of key functions. The various LEDs and the associated functions are illustrated above. In addition, the "ENABLED" LED provides indication that the SEL-451 relay is powered on and the "TRIP" LED illuminates when the relay has initiated a transfer operation

(Previously shown in December 2011 Newsletter)

Field Selectable Functions

To simplify entry of this information and to permit its quick review on the laptop computer, the field-selectable functions are grouped in the “MM Transfer Settings” screen, which is accessed through the software program supplied with the switchgear. The applicable pull-down screen in the software is illustrated in Figure 11.

The field-selectable functions are:

CT Ratios for Source 1 and Source 2

PT Ratios for Source 1 and Source 2

Over-Current Enabled — Y = Enabled; N= Disabled — Over-current Lockout is enabled or disabled

Over-Current Level for Source 1 and Source 2 — current level above which an over-current condition exists

Over-Current Lockout Timer (seconds) — time the over-current is allowed to exist before declaring an over-current lockout

Source 1 Initial Transfer Delay Timer (seconds) — time after dead source is declared before a transfer is initiated when Source 1 is the preferred source

Source 1 Return Transfer Delay Timer (seconds) — time after return of source voltage before a retransfer to the preferred source is initiated when Source 1 is the preferred source and Auto Retransfer is enabled

Source 2 Initial Transfer Delay Timer (seconds) — time after dead source is declared before a transfer is initiated when Source 2 is the preferred source

Source 2 Return Transfer Delay Timer (seconds) — time after return of source voltage before a retransfer to the preferred source is initiated when Source 2 is the preferred source and Auto Retransfer is enabled

Generator as Alternate — Y=yes and N=no — apply Y when alternate source is a generator; otherwise apply N

Source Paralleling — Y=yes and N=no — apply Y when paralleling sources on Return Transfer is permitted; otherwise apply N

Return Transfer Sequence (Open or Closed) — select open or closed transition return on retransfer to the preferred source: Open prevents paralleling on retransfer; Closed permits paralleling on retransfer

CDT (seconds) — Generator Cool Down Timer (applicable only when the alternate source is a generator)

Generator Stop Pulse Duration (seconds) — Time that the generator stop contact will remain closed

Auto Retransfer (Y — Enabled, N — Hold for retransfer) — select automatic return on retransfer to the preferred source or hold return on retransfer to the preferred source

Dead Source Voltage (volts) — phase-to-neutral primary voltage required to declare a dead source

Live Source Voltage (volts) — phase-to-neutral primary voltage required to declare a live source

Voltage Unbalance (volts) — Zero sequence voltage required to declare a voltage unbalance bad source (designated as 3V0)

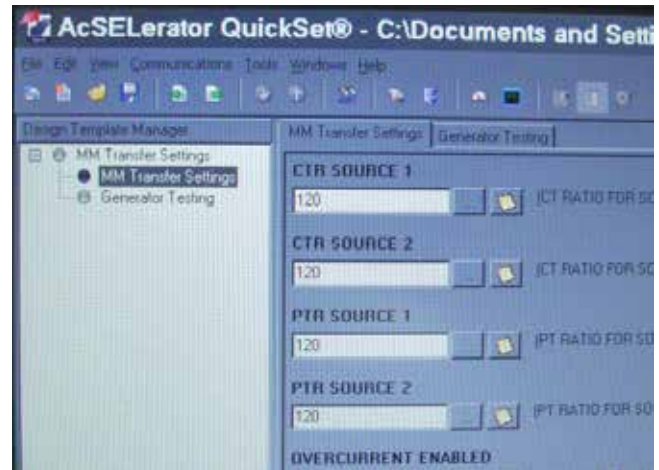

Figure 11. The Field Selectable functions are found in the “MM Transfer Settings” screen within the imbedded software furnished with the pad-mounted switchgear. Two drop-down menus are provided. When the service is from two utility sources the functions are included on the “MM Transfer Settings”. When the alternate source is a standby generator, additional field-selectable functions are provided and these are found in the “Generator Testing” tab.

(Previously shown in December 2011 Newsletter)

This document contains proprietary information of Electro-Mechanical Corporation or its operating divisions in whom title remains. Any reproduction, distribution, disclosure or use not otherwise expressly approved in writing is strictly prohibited. Designated trademarks and brands are the property of their respective owners.

