

FP AUTOMATIC METAL-ENCLOSED SWITCHGEAR

5kV through 38kV



Four-bay assembly of Federal Pacific Automatic Source-Transfer Switchgear featuring Federal Pacific Automatic-Transfer Micro-Processor Control, switch operators and load-interrupter switches.

Federal Pacific of Bristol, Virginia offers power-operated metal-enclosed switchgear in two basic styles: Automatic-Transfer Metal-Enclosed Switchgear and Shunt-Trip Metal-Enclosed Switchgear. These two styles can be mixed within a switchgear assembly. In addition, other automatic and supervisory-control switching functions may be integrated into the two basic styles. The basic styles of Federal Pacific Power-Operated Metal-Enclosed Switchgear are discussed in the paragraphs that follow.

Automatic Transfer

Federal Pacific offers Automatic Source-Transfer Switchgear for those applications where alternate sources of power are essential for continued operation of critical loads. This switchgear features an automatic-transfer control relay as shown in Figure 1 on page 138, to monitor system conditions. The automatic-transfer relay is the SEL-451, which automatically initiates transfer to an alternate power source if voltage on the preferred source, reduces below a preset level.

Federal Pacific Automatic-Transfer Metal-Enclosed Switchgear combines Federal Pacific Auto-Jet® II Load-Interrupter Switches

with motor operators and the SEL-451 relay. These components are all mounted within rigid, panel constructed, self-supporting enclosures. Low-voltage components, such as the source transfer control relay and motor operators, are isolated from medium voltage in the switchgear bay door or side stile. Alternately, for Fast-Trip Transfer the motor operators may be mounted on the side of the switchgear bay in secure low-voltage enclosures.

Federal Pacific offers two basic types of Automatic-Transfer motor operators: **Run & Trip** and **Fast-Trip Transfer Stored Energy**.

Run & Trip employs a motor operator on the shaft of the standard Auto-jet® switch. When called to operate, the motor charges the spring of the switch in a similar manner to charging the switch manually. As the spring reaches its trip point, the switch blades operate in the direction for which the spring was charged (to open or to close). With the run-and-trip motor operators, transfer is achieved in approximately eight (8) seconds. The motor operators are mounted in the switchgear bay stile (as illustrated in Figure 2 on page 135), replacing the manual handle, and requiring no extra space.

For **Fast-Trip Transfer**, the motor operator is mounted on the side of the switchgear bay in a secure low-voltage compartment and directly coupled to the switch operating shaft. See Figure 3 on page 135. On loss of source voltage, the motor automatically charges and trips the springs of the switch mechanism and instantly trips the switches in approximately 20 cycles. To trip the switch, the motor charges and releases the spring energy, opening or closing the switch blades.

Employing **Fast-Trip Transfer**, the switch will trip faster (by high-speed revolution of the charging motor) after the open or close signal is received, rather than taking a few seconds to charge a spring as is done by the **Run & Trip** mechanism. But, the speed difference may not be a significant consideration for most applications. There are two transfer times that are significant: 1/4 cycle (5 milliseconds) and two cycles (33 milliseconds). The 1/4 cycle (5 millisecond) transfer will allow micro-processor circuits to remain powered and operational. The two cycles (33 millisecond) will allow metal halide lamps serving stadiums and arenas to stay lit. Beyond these two very short duration transfer times, there are limited advantages for the relative transfer-speed difference between **Fast-Trip Transfer** (with an approximate 20-cycle transfer time) and **Run & Trip** transfer.

Run & Trip has the advantage of lower initial cost where speed of operation is not an issue.

The Federal Pacific Automatic Transfer Switchgear is available in ratings through 38 kV for either indoor or outdoor installation and can accommodate a variety of power fuses - both current-limiting fuses and expulsion-type fuses. Federal Pacific automatic-transfer metal-enclosed switchgear provides automatic two-way source transfer with the ability to connect either of two utility sources (or a utility source and a standby generator) to the switchgear bus. In automatic-transfer switchgear, referred to as common-bus primary-selective systems, one incoming line switch is closed (preferred source) and the other incoming line switch is open (alternate source).

Bus-tie configurations requiring operation and control of more than two switches are also available and are referred to as split-bus primary-selective systems. In split-bus systems, two or more

incoming source switches are closed each supplying power to an independent bus-section, which are separated by a normally open bus-tie switch. If power to a bus section is lost, the associated incoming source switch opens and the adjacent bus-tie switch closes, restoring power to the bus section. Federal Pacific's core engineering staff can provide various types of other automatic or supervisory switching applications. For example, SCADA control interface is also available with automatic transfer.

Automatic-Trip (Shunt-Trip) Applications

The Federal Pacific Shunt-Trip Switch (UL Listing available for 5kV and 15kV applications) can be applied where there is an automatic tripping requirement in response to system deviations from normal conditions. Applications include: loss of voltage, over-voltage, incorrect phase rotation, transformer-overload and blown fuse (the most common reason).

Federal Pacific employs two very reliable methods for sensing a blown fuse, creating a single-phase condition. The first method is a conventional set of VTs connected to a Phase-Loss Relay (PMR); when sensing a loss of phase output voltage supplied by VTs, the PMR closes the contacts, which actuates the solenoid (powered by a capacitor), to trip the switch open. A switchgear bay equipped with shunt-trip capability is illustrated in the photos below.

The second method uses a current-limiting fuse blown-fuse indicator, which pushes the end of a cable to close the contact to activate the solenoid, which correlates to the PMR closing the contact in the first method. Using the blown-fuse indicator pin eliminates the need for a phase-loss relay (PMR) and is usually a lower cost method of single-phase protection. A picture of the cable assembled to the current-limiting fuse mount is shown in Figure 2 (on page 136).

Also illustrated is the Federal Pacific standard Auto-Jet® II switch equipped with the shunt-trip solenoid and latch module (shown in Figure 3 on page 136) and an auxiliary switch with contacts for remote indication.



Pictured above are typical feeder bays with automatic-trip (shunt-trip) switches, providing feeder isolation when a single-phase condition (such as a blown feeder fuse) occurs.



Figure 1. Type ME Motor Operators are mounted in the switchgear stile, adjacent to the compartment door opening and allowing the enclosure width to remain at only 36 inches. Federal Pacific's source-transfer relay is mounted on the switchgear in a separate low-voltage enclosure. As pictured above, the SEL-451 relay is mounted on the compartment door of the second bay from right.



Figure 2. Hinged, gasketed cover protects motor operator from the environment and internal heater keeps air circulating to dry the interior.



Figure 3. Automatic-transfer switchgear with Fast-Trip Transfer motor operators is pictured in the photo above. Transfer to the alternate source is achieved in approximately twenty (20) cycles.

Shunt-Trip Employing VTs With Phase-Loss Relay (PMR) for Sensing and Tripping

Operation

Charging Switch:

Before the shunt-trip switch will operate manually or electrically, it is necessary to first close the switch, then charge and latch the switch operating mechanism spring so it is ready to trip open. The switch can then be tripped open manually by pulling a knob located below the handle or electrically either automatically by detecting a phase loss or remotely by initiating a trip signal by supervisory control from a distant location, if the latter option is specified and provided.

Loss of One or Two Phases:

Upon loss of one or two phases, the phase-loss relay will pick up after the preset time delay (2, 4, 6 or 8 seconds field selectable). When the phase-loss relay contact closes, the capacitor-trip device (CTD) discharges into the shunt-trip solenoid (ST). The solenoid pulls the latch holding the previously compressed mechanism spring on the switch (refer to "Charging Switch"). The switch opens, which opens a limit-switch contact (switch-position contact), thereby turning off power to the shunt-trip solenoid. After restoring power to the affected phases, manual closing and charging is then required to reset the switch latched for the next shunt-trip operation.

Shunt-Trip Using CLF Blown-Fuse Indicator To Close The Tripping Contacts

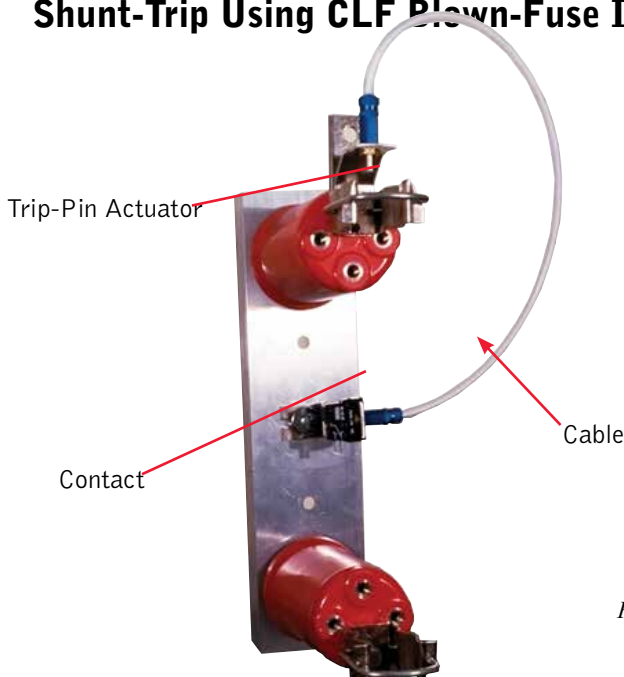

Current-limiting fuse mountings equipped with a trip-pin actuated cable release (as pictured at left) will initiate the tripping sequence to the mechanism on the charged and latched shunt-trip switch. When the fuse operates, the blown-fuse indicator is propelled upward and protrudes through the top of the fuse. The indicator engages the trip-pin actuator to move the cable that activates the contact, which causes the solenoid on the switch frame to release the latch and thereby trip the stored-energy mechanism, opening the switch.

Figure 2

Three-Phase Auto-jet® II Switch Equipped with Shunt-Trip Latch and Solenoid

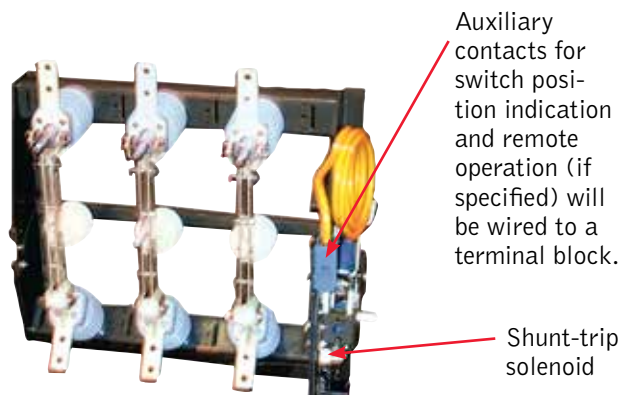

Shunt-trip switch pictured at left is equipped with an auxiliary switch with contacts wired to a terminal block within the switch-gear. These contacts reflect switch position (open or closed), allowing the actual switch position to be determined from a remote location. They can also be wired (optionally) to allow trip-open operations to be initiated by supervisory control from a distant location.

Figure 3

Switch Operators for Metal-Enclosed Switchgear

Fast-Trip Switch Operator

Fast-Trip Switch Operator includes switch-position indicator, decoupling lever, decoupling indicator, operation counter, shaft to manually charge switch if control power is lost, emergency manual tripping and pushbuttons for local operation. Decoupling lever isolates switch from the switch operator so that functional testing can be performed without opening and closing the switches . . . the load circuit remains energized.

1. Switch operator crank handle
2. Aluminum enclosure
3. Switch output shaft
4. Switch position indicator
5. Padlockable stainless-steel handle
6. 24V DC battery
7. Battery charger control circuit
8. Removable plate for conduit entry of low-voltage wiring at bottom of enclosure
9. Open/close indicating lamps
10. Operation counter (optional - not shown)
11. Open/close toggle switch
12. Local/remote selector switch
13. Control-source fuses
14. Continuous stainless-steel hinges
15. Gasketed door opening
16. Door holder
17. Fast-Trip Motor - Cover interlocked to prevent motor operation when open
18. Run-and-Trip Motor



Run & Trip Switch Operator

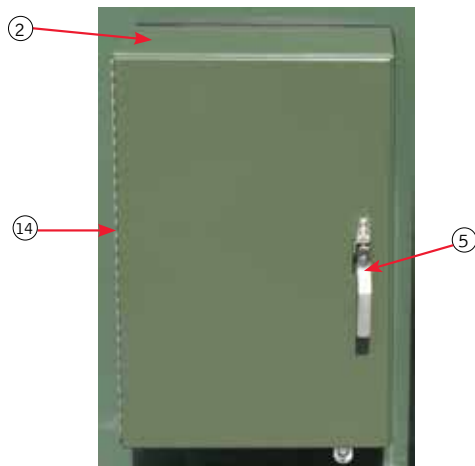

Figure 4. Enclosure of Run-and-Trip motor operator.

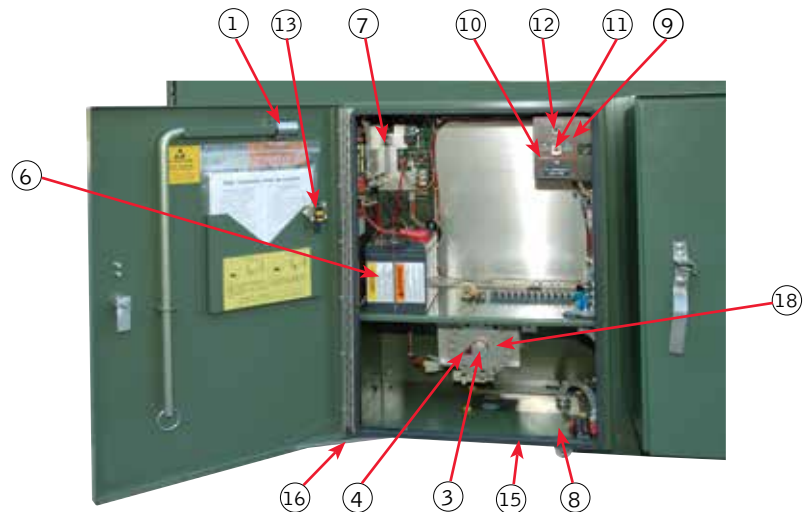

Figure 5. Interior of Run-and-Trip motor operator.

Automatic
Metal-Enclosed Switchgear

Automatic-Transfer Relay Control

Federal Pacific Automatic-Transfer Metal-Enclosed Switchgear utilizes the Federal Pacific Automatic-Transfer Software Program in the SEL-451 relay. The relay monitors system conditions and automatically initiates transfer to an alternate power source if voltage on the preferred source reduces below a preset level. Federal Pacific switch operators actuate opening and closing of the Federal Pacific Auto-jet® II load-interrupter switches.

The conditions required to initiate automatic switching are field selectable and are discussed under "Field Selectable Functions" on page 138.

The Federal Pacific automatic-transfer relay utilizes a state-of-the-art electronic controller to perform operations that are directed by settings programmed into the device at the factory and in the field. Such parametric characteristics as voltage-, current-, and time-related operating parameters are entered into the control by means of a laptop computer. The entries are readily viewed on the laptop computer screen display. Internal memory with back-up battery records events and maintains a log, allowing diagnostic capability.

Automatic-Transfer Relay Control



Figure 1. View of typical low-voltage control cabinet (above) that includes the automatic-transfer control relay and associated components.

Field Selectable Functions

To simplify entry of this information and to permit its quick review on the laptop computer, the field-selectable functions are grouped in the "MM Transfer Settings" screen, which is accessed through the software program supplied with the switchgear.

The field-selectable functions are:

CT Ratios for Source1 and Source 2

PT Ratios for Source 1 and Source 2

Over-Current Enabled — Y = Enabled; N= Disabled — Over-current Lockout Is enabled or disabled

Over-Current Level for Source 1 and Source 2 — current level above which an over-current condition exists

Over-Current Lockout Timer (seconds) — time the over-current exists before declaring an over-current lockout

Source 1 Initial Transfer Delay timer (seconds) — time after dead source is declared before a transfer is initiated when Source 1 is the preferred source

Source 1 Return Transfer Delay timer (seconds) — time after return of source voltage before a retransfer to the preferred source is initiated when Source 1 is the preferred source and Auto Retransfer is enabled

Source 2 Initial Transfer Delay timer (seconds) — time after dead source is declared before a transfer is initiated when Source 2 is the preferred source

Source 2 Return Transfer Delay timer (seconds) — time after return of source voltage before a retransfer to the preferred source is initiated when Source 2 is the preferred source and Auto Retransfer Is enabled

Generator as Alternate — Y=yes and N=no — apply Y when alternate source is a generator; otherwise apply N

Source Paralleling — Y=yes and N=no — apply Y when paralleling sources on Return Transfer is permitted; otherwise apply N

Return Transfer Sequence (Open or Closed) — select open or closed transition return on retransfer to the preferred source

CDT (seconds) — Generator Cool Down Timer (applicable only when the alternate source is a generator)

Generator Stop Pulse Duration (seconds) — Time that the generator stop contact will remain closed

Auto Retransfer (Y — Enabled, N — Hold for retransfer) — select automatic return on retransfer to the preferred source or hold return on retransfer to the preferred source

Dead Source Voltage (volts) — phase-to-neutral primary voltage required to declare a dead source

Live Source Voltage (volts) — phase-to-neutral primary voltage required to declare a live source

Voltage Unbalance (volts) — Zero sequence voltage required to declare a voltage unbalance bad source (designated as 3V0)

Functional Status LEDs

Additional functional status conditions for both sources are indicated by twenty-four (24) available illuminated LEDs with labels on the faceplate of the relay.



Figure 2. functional status LEDs and labels.

These LEDs provide indications as follows:

Over-Current Suspend — Illuminates when an over-current has occurred and resets off if there is no loss of source voltage

Over-Current Lockout — Illuminates when an over-current occurs that is followed by a loss-of-source voltage

M1 Decouple — Motor 1 is decoupled — Capability displays for Motor 1 whether the mechanism is decoupled from the switch (LED illuminated) or coupled (LED not illuminated) to the associated switch

M1 No Go — LED is illuminated when Motor 1 has malfunctioned; otherwise LED is not illuminated

M1 Batt/Chg — Motor 1 Battery or Battery Charger has malfunctioned — LED is illuminated when Motor 1 battery or battery charger has malfunctioned; otherwise LED is not illuminated

M1 Cls/Opn — Motor 1 is Closed or Open — LED is illuminated green when Motor 1 is open; illuminated red when Motor 1 is closed

M1 Rem/Lcl — Motor 1 is in Remote or Local — LED is illuminated when Motor 1 is in remote; otherwise LED is not illuminated

M2 Decouple — Motor 2 is decoupled — Capability displays for Motor 2 whether the mechanism is decoupled from the switch (LED illuminated) or coupled (LED not illuminated) to the associated switch

M2 No Go — Motor 2 has malfunctioned — LED is illuminated when Motor 2 has malfunctioned; otherwise LED is not illuminated

M2 Batt/Chg — Motor 2 Battery or Battery Charger has malfunctioned — LED is illuminated when Motor 2 Battery or Battery Charger has malfunctioned; otherwise LED is not illuminated

M2 Cls/Opn — Motor 2 is Closed or Open — LED is illuminated green when Motor 2 is open; illuminated red when Motor 2 is closed

M2 Rem/Lcl — Motor 2 Is in Remote or Local — LED Is illuminated when Motor 2 is In remote; otherwise LED is not Illuminated

Mismatch — Motor 1 and Source Switch 1 or Motor 2 and Source Switch 2 are not in the same positions — LED Is illuminated when Motor 2 is In remote; otherwise LED is not Illuminated

S1VA, S1VB and, S1VC — illumination of the LED establishes for the applicable Source 1 phase whether the associated source voltage is available (above minimum conditions) or, if the LED is not illuminated, that source voltage is not available (below minimum conditions) on the associated phase

S2VA, S2VB and, S2VC — illumination of the LED establishes for the applicable Source 2 phase whether the associated source voltage is available (above minimum conditions) or, if the LED is not illuminated, that source voltage is not available (below minimum conditions) on the associated phase



Figure 3. Interactive soft keys include LED lamp and label.

Interactive Soft Keys

A grouping of twelve (12) interactive soft keys combined with status LEDs and labels allow surface selection and actuation of a number of operating choices.

The interactive soft keys that provide Local Operation capability on the faceplate of the SEL-451 relay include:

Open/Close keys for each source switch — Capability allows actual open and close operations of the associated switch and also illuminates an LED to display for each source the actual switch position (“Switch Open” — green or “Switch Closed” — red) of the associated switch.

Auto or Manual operation selection — establishes operating mode of the relay — actual mode is set by depressing the applicable soft key and status is indicated by illumination of the LED that is adjacent to the two soft keys labeled “Auto” and “Manual” in a green color, designating the present mode

Source 1 or Source 2 selected as the preferred source — capability for each source switch to provide service as the “Preferred” source, which provides power to the load under normal conditions, or as the “Alternate” source, which provides power to the load when the preferred source is not available.

Hold Return — Return to preferred source — if the “Auto Retransfer” MM Setting is disabled

Remote Enabled — capability for units furnished with SCADA interface to position the control in “Enabled” or “Disabled” mode. The control is by default in “Disabled” mode and can only be placed in “Enabled” mode through user positioning the interactive soft key on the faceplate of the relay as Indicated by Illumination of the associated LED

Reset Over-Current Lockout — allows reset of the over-current lockout condition touch the labeled soft key to reset the control following an overcurrent lockout condition. The associated LED is flashing red when an overcurrent lockout condition exists.

Generator Start/Stop — enabled if the alternate source is a generator



Figure 4. SEL-451 LCD display.

LCD Display

A large LCD display on the faceplate of the relay will continuously and automatically scroll through ten (10) primary display points.

The primary display points include functions as follows:

Phase Currents for Source 1 and Source 2

Phase Voltages for Source 1 and Source 2

Mismatch for Motor 1 and Motor 2 — shows whether the motor and the switch are in the same position to permit coupling

UPS Battery Voltage — status of battery voltage (adequate or low)

Battery Charger — Status of AC input to the battery charger

Faulted Phase — Identification of the phase on which a fault has occurred

Permissive Generator Start — Status of start key if the alternate source is a generator

The LCD display also supports a Main Menu screen that allows access to:

EVENTS Log — provides date/time stamp on events and current/voltage at time of event

SET/SHOW — Function provides the facility to edit the DATE/TIME

DISPLAY TEST — Function provides the facility to perform a lamp test of all the LEDs to verify functionality of all LEDs

STANDARD SPECIFICATIONS FOR MANUAL METAL-ENCLOSED SWITCHGEAR

A. General

1. Product

The metal-enclosed switchgear shall be in accordance with the applicable plans, drawings and one-line diagrams and shall conform to these specifications.

2. Assembly

The metal-enclosed switchgear assembly shall consist of one or more indoor, outdoor self-supporting bays, containing interrupter switches and/or power fuses with the necessary accessory components, all completely factory assembled and operationally checked.

3. Ratings

a) Ratings for the integrated switchgear assembly shall be as designated below. Select appropriate column.

System Voltage Class								
	5kV		15kV		25kV	25kV	35kV	35kV
kV, Nominal	4.16		14.4		24.9	24.9	34.5	34.5
kV, Maximum Design	5.5		17.5		27	27	38	38
kV, BIL	60		95		125	125	150	200
Main Bus Continuous Amp	600	1200	600	1200	600	1200	600	1200
Switch Load Interrupting	600	1200	600	1200	600	1200	600	—
Short-Circuit Ratings ①								
Amps, RMS Symmetrical	25,000	38,000	25,000	38,000	25,000	25,000	25,000	38,000*
MVA 3-Phase Symmetrical at Rated Nominal Voltage	180	275	625	950	1,000	1,000	1,500	1,500
Fault-Closing Amps, RMS Asym 3-Times Duty-Cycle ②	40,000	40,000	40,000	40,000	40,000	40,000	40,000	—
Fault-Closing Amps, RMS Asym 1-Time Duty-Cycle ③	—	61,000	—	61,000	—	—	—	—

- ① These are nominal switch ratings. Integrated switchgear unit may be limited by fuse ratings. Use the fuse ratings charts in this publication to adjust short circuit ratings, when applicable.
- ② The three-time duty-cycle fault-closing rating means that the switch can be closed 3 times into rated fault amperes and remain operable and able to carry and interrupt its rated load current.
- ③ The one-time duty-cycle fault-closing rating means that the switch can be closed 1 time into rated fault amperes and remain operable and able to carry and interrupt its rated load current.
- * The asymmetrical rating is 61,000 amperes, one-second.

b) For cubicles or bays in which overcurrent circuit protection is required on circuits, where the continuous load amperes exceed the maximum continuous ampere rating of a single fuse, a drawout circuit breaker should be specified in preference to employing paralleled expulsion fuses whose arcing products and pressures may be substantial during the interruption of fault current.

4. Certification of Ratings

a) The integrated metal-enclosed switchgear assembly shall be designed and built by the manufacturer of the basic interrupter switch who shall be completely

and solely responsible for the performance of these basic components as well as the complete integrated assembly as rated.

b) The manufacturer shall furnish upon request certification of ratings for the basic switch and fuse components and/or the integrated metal-enclosed switchgear assembly consisting of the switch and fuse components in combination with the enclosure(s).

5. Compliance with Standards and Codes

- a) ANSI C37.20.3 and IEEE Standard 27 (Standards for Switchgear Assemblies including Metal-Enclosed Bus).
- b) Applicable safety and health standards promulgated pursuant to Federal Occupational Safety and Health Act of 1970.
- c) Article 490.21(E) "Load Interrupter" in the National Electrical Code, which specifies that the interrupter switches in combination with power fuses shall safely withstand the effects of closing, carrying, and interrupting all possible currents up to the assigned maximum short-circuit rating.
- d) (Optional) The switchgear assembly shall be UL listed. (Available on 5kV and 15kV switchgear only.)

B. Construction — Assembly:

1. Insulators

The interrupter-switch and fuse-mounting insulators shall be a cycloaliphatic epoxy resin system with material characteristics and restrictions as follows:

- a) Operating experience of at least twenty (20) years under similar conditions.
- b) Ablative action to ensure non-tracking properties.
- c) Adequate leakage distance established by test per IEC Standard 60507.
- d) Adequate strength for short-circuit stress established by test.
- e) Conformance with applicable ANSI and IEEE standards.
- f) Homogeneity of the cycloaliphatic epoxy resin throughout each insulator to provide maximum resistance to power arcs. Ablation due to high temperatures from power arcs shall continuously expose more material of the same composition and properties so that no change in mechanical or electrical characteristics takes place because of arc-induced ablation. Furthermore, any surface damage to insulators during installation or maintenance of the metal-enclosed gear shall expose material of the same composition and properties so that insulators with minor surface damage need not be replaced.

2. High-Voltage Bus

a) Bus and interconnections shall consist of aluminum bar of 56% IACS conductivity.

- b) Bolted aluminum-to-aluminum connections (copper is optional) shall be made with a suitable number of non-corrosive bolts and nuts, and with two Belleville spring washers per bolt, one under the bolt head and one under the nut or with a wide, flange-head carriage bolt and one Belleville spring washer per bolt. As an alternate, bolted aluminum-to-aluminum connections shall be made with a suitable equivalent surface area, i.e. 1-bolt and spring washer. Bolts shall be tightened to proper torque for the particular Belleville washer.

3. Ground Bus

- a) A ground bus of short-circuit rating equal to that of the integrated assembly (or a ground connection, in the case of single-bay switchgear) shall be provided, maintaining electrical continuity throughout the integrated assembly.
- b) The ground bus shall consist of aluminum bar of 56% IACS conductivity.
- c) In each bay, the ground bus (or connector) shall be bolted to a stainless steel bracket, which shall be welded to the enclosure (copper is optional).

C. Construction - Enclosure & Finish

1. Enclosure

- a) The enclosure of each bay shall be constructed of heavy-gauge formed steel panels that maximize strength, minimize weight, and inhibit internal corrosion. (Optional all welded construction is also available.) For Category A only: externally removable bolted panels will not be accepted unless specified and when specified must be installed with tamper-resistant hardware.
- b) The basic material for the enclosure, roof and doors shall be 11-gauge, hot-rolled, pickled-and-oiled steel sheet.
- c) Each bay containing high-voltage components shall be a complete unit in itself, with full side sheets resulting in double-wall construction between bays. To guard against unauthorized or inadvertent entry, side and rear sheets shall not be externally attached with removable bolts except where tamper-resistant hardware is specified.
- d) Sufficient space shall be allowed for ease of cable pulling and installation. Space shall be free from fixed structural members or electrical devices.
- e) On multi-bay units when "thru-bushings" between the cubicles are specified, the thru-bushings should be shipped completely assembled to the cubicle and shall not require field assembly of semi-conducting grommets.

2. Doors

- a) Doors shall be constructed of 11-gauge hot-rolled, pickled-and-oiled steel sheet.
- b) Door edge flanges shall overlap with door opening flanges and shall be formed to create a mechanical maze that shall guard against water entry and discourage tampering or insertion of foreign objects.
- c) Doors shall have an appropriate number of hinges based on door height and, in no case, less than three when door height exceeds forty (40) inches. The hinges and hinge

pins shall be stainless steel and secured in place to guard against tampering.

- d) In consideration of controlled access and tamper resistance, each door shall be equipped with a positive-action three-point latching system.
- e) Doors providing access to fuses shall have provisions to store spare fuse units or refill units.
- f) Each door is provided with a door holder to hold the door open against inadvertent closing. It shall be integral with the door and frame and shall self-secure when the door is fully opened.

For units specified with optional Category A features:

- g) Each door shall be provided with a recessed stainless-steel door handle. The door handles shall be padlockable and shall incorporate a hood to protect the padlock shackle from tampering. Each handle shall be provided with a recessed (select the hex or penta-head) bolt for additional security.

3. Access Control

- a) Doors providing access to interrupter switches with power fuses shall be mechanically or key interlocked to guard against:
 - 1) Opening the door if the interrupter switch on the source side of the power fuse is closed, and
 - 2) Closing the interrupter switch if the door is open.
- b) Doors providing access to interrupter switches only shall have provisions for padlocking.
- c) Each bay or compartment thereof containing high-voltage components shall be provided with a protective screen or second door, bolted closed, to guard against inadvertent entry to bays containing these components when the enclosure door is open.
- d) Access to the enclosure shall be from the front only, unless otherwise specified (for example) for cable termination at rear.

4. Vents

Ventilation openings shall be provided at the top and bottom of the unit as required for proper air circulation. Vents shall have stainless steel screened interior baffles to prevent entrance of foreign objects.

5. Lifting Eyes

Lifting provisions shall be removable and shall not permit entry into the interior when removed.

6. Finish

- a) Full coverage at joints and blind areas shall be achieved by processing enclosure panels or welded enclosures independently of components such as doors and roofs before assembly into the unitized structures.
- b) All surfaces shall undergo a chemical cleaning, phosphatizing or zirconization and sealing before any protective coatings are applied in order to remove oils and dirt, form a chemically and anodically neutral conversion coating, improve the finish-to-metal bond, and retard underfilm propagation of corrosion.
- c) The finishing system shall be applied without sags or runs for a pleasing appearance.

- d) After the enclosure is completely assembled and the components (switches, bus, etc.) are installed, the finish shall be inspected for scuffs and scratches. Blemishes shall be carefully touched up to restore the protective integrity of the finish.
- e) Unless otherwise specified, the color shall be ANSI 61 Light Gray.
- f) To assure that the finishing system is capable of resisting corrosion, the manufacturer shall provide if requested certification that representative test panels, protected by the manufacturer's finish system, have passed the following tests:
- 1) **Salt spray** (relates to coastal environments and/or presence of snow-melting salts or fertilizers). Scribe to bare metal and test for 2000 hours in a 5% salt spray per ASTM B-117. Loss of adhesion from bare metal should not extend more than 1/8" from the scribe. Underfilm corrosion should not extend more than 1/16" from the scribe.
 - 2) **Crosshatch adhesion** (relates to adhesion after scratching of the finish). Scribe to bare metal a crosshatch pattern of 100 1/16" wide squares. Apply Scotch 710 tape and rapidly remove. There should be 100% adhesion to the bare metal and between layers.
 - 3) **Humidity** (relates to environments with high humidity). Test for 1000 hours subject to 100% humidity at 45-50°C per ASTM 2247. There should be no blisters.
 - 4) **Impact** (relates to transit and handling damage and abuse by public). Impact the test panel with a 160 in.-lb., falling dart per ASTM D-2794. There should be no cracking or chipping of the paint on the impact side of the test panel.
 - 5) **Oil Resistance** (relates to probable contact with mineral oil). Immerse two test panels in mineral oil for 3 days, one at room temperature and one at 100°C (212°F). There should be no apparent changes, such as color shift, blisters, loss of hardness or streaking.
 - 6) **Ultraviolet Accelerated Weathering Test** (Relates to exposure to sunlight and rainfall, loss of gloss, color fading, and chalking). Continuous exposure to ultraviolet light for 500 hours per ASTM G-53 with a cycle of 4 hours ultraviolet followed by 4 hours of condensation. Loss of gloss should not exceed 50% of original gloss per ASTM D-523.
 - 7) **Water Resistance** (relates to rainfall or dew). Immerse a test panel in distilled water for 3 days at room temperature. There should be no apparent changes, such as blistering, color shift, loss of hardness or streaking.
 - 8) **Adhesion** — Fed Spec. 141A, Method 6301.1 (relates to adhesion after scratching the finish). Immerse test panel in distilled water for 24 hours. Make two parallel scratches 1" apart. Apply Scotch 710 tape and rapidly remove. There should be 100% adhesion to the bare metal and between layers.

- 9) **Abrasion Test** — Taber Abrader (relates to wear encountered during installation). Prepare a panel coated with the component of the finish intended to provide abrasion resistance. Test using a CS-10 wheel, 1000 gram weight, 3000 cycles, per Fed. Spec. 141, Method 6192. This provides a comparative test between samples.

- g) To guard against corrosion, all hardware (including door fittings, fasteners, etc.), all operating-mechanism parts, and other parts subject to abrasive action from mechanical motion shall be of nonferrous materials, galvanized, or zinc chromate plated ferrous materials. Cadmium plated ferrous parts shall not be used.

D. Basic Components:

1. Interrupter Switches

- a) Interrupter switches shall have a three-time duty-cycle fault-closing rating equal to or exceeding the short-circuit rating of the integrated switchgear assembly. These ratings define the ability to close the interrupter switch either alone (un-fused) or in combination with the appropriate fuses three times against a three-phase fault with asymmetrical current in at least one phase equal to the rated value, with the switch remaining operable and able to carry and interrupt rated current. Tests substantiating these ratings shall be performed at maximum design voltage with current applied for at least 10 cycles. Certified test abstracts establishing such ratings shall be furnished upon request.
- b) Interrupter switches shall be completely assembled and adjusted by the switch manufacturer on a single rigid mounting frame.
- c) Interrupter switches shall be provided with contact blades and interrupters for circuit closing, including fault-closing, continuous current carrying, and circuit interrupting. Interrupter switches with auxiliary blades shall not be permitted.
- d) Interrupter switches shall be positively and inherently sequenced with the blade position. It shall not be possible for the blade and interrupter to get out of sequence.
- e) Interrupter switches shall have a readily visible open gap when in the open position to allow positive verification of correct switch position.
- f) Each interrupter switch shall be provided with a switch operating handle. The handle shall be non-removable, and provisions shall be provided for padlocking in open or closed position.
- g) Interrupter switches shall utilize a quick-make, quick-break mechanism installed by the switch manufacturer. The quick-make, quick-break mechanism shall be integrally mounted on the switch frame, and shall swiftly and positively open and close the interrupter switch independent of the speed of the switch operating handle.

2. Fuses

- a) Fuses shall be solid-material power fuses or current-limiting fuses as specified by the equipment purchaser.

- b) Each bay containing fuses shall be equipped with grounding provisions on the load side of the fuses and on the ground bus.

3. Metering

- a) Primary-metering compartment shall be provided as required.
- b) Access to metering compartment shall be provided with a protective screen or second door, bolted closed to guard against inadvertent contact with energized parts when the main enclosure door is open.
- c) Metering transformers shall be mounted such that established electrical clearances are maintained.
- d) All low-voltage wiring shall be located as required to minimize exposure to high voltage.

E. Labeling

1. Hazard-Alerting Signs & Labels

- a) All external doors and hinged bolted panels providing access to high voltage shall be provided with suitable hazard-alerting signs.
- b) All internal screens or doors providing access to high voltage shall be provided with "Danger" signs.
- c) All internal screens or doors providing access to interrupter switches shall be provided with danger signs indicating "Switch Blades May Be Energized in Any Position".
- d) All internal screens or doors providing access to fuses shall be provided with danger signs indicating "Fuses May Be Energized in Any Position".

2. Nameplate, Ratings Labels, & Connection Diagrams

- a) The outside of a single or multi-compartment switchgear assembly shall be provided with a nameplate indicating the manufacturer's name, catalog number, date of manufacture, and serial number.
- b) The inside of each door shall be provided with a ratings label indicating the following: voltage ratings; main bus continuous rating; short-circuit ratings (amperes rms symmetrical and Mva three-phase symmetrical at rated nominal voltage); the type of fuse and its ratings including duty-cycle fault-closing capability; and interrupter switch ratings including duty-cycle fault-closing and short-time (momentary, amperes rms asymmetrical and one-second, amperes rms symmetrical).
- c) A one-line connection diagram showing interrupter switches, fuses, bus, and auxiliary equipment shall be provided as a drawing with each switchgear assembly.

F. Accessories

1. Fuse units or refill units, and voltage-transformer fuses for original installation and for spares shall be furnished as specified by the equipment purchaser.
2. A fuse handling tool as recommended by the fuse manufacturer shall be furnished as specified by the equipment purchaser.

G. Routine Production Tests

Production tests are those tests made to check the quality and uniformity of the workmanship and materials used in the manufacture of the switchgear. The unit shall meet the production tests described below, 1 through 3 inclusive.

1. Circuit Resistance Test

The purpose of this test is to verify that all load-interrupter switch contacts have been properly aligned and current transfer points have been properly assembled.

The DC resistance of the current carrying circuit of each switch phase from terminal to terminal of each pole in the closed position shall be measured with current of at least 10 amperes flowing. The resistance shall not exceed a limit specified by the manufacturer.

2. Dielectric Tests

Insulation withstand tests are made of the completely assembled unit to determine the ability of the insulating materials and spacing to withstand overvoltages for a specified time without flashover or puncture.

3. Operating Assurance Tests

Each switch shall be operated mechanically and tested to verify:

- a) That the switch position indicators and contacts are in correct position for both open and closed positions.
- b) That the unit circuit configuration is shown correctly.

H. Outdoor Units

In addition to the above requirements, outdoor units shall be provided with space heaters in each bay. The space heaters shall be enclosed within a perforated guard. Heater shall be fused and wired to a terminal block.

The edges of the top and sides of adjacent bays shall be covered to prevent water entry. Roof and bay interface shall be covered between each bay to prevent water entry.

For multi-bay units the roof construction shall be made with a roof cap channel where the cubicles are joined as shown in the drawing entitled Outdoor Roof Construction. (See Figure 8.)

Louvers on outdoor units shall include backup plates with stainless steel screens.

Rated Max. Voltage, kV	Rated Withstand Impulse Voltage, kV	Production Test, kV, RMS 60 Hz
5.5	60	19
17	95	34
27	125	40
38	150	80
38	200	80

The Metal-Enclosed Switchgear must comply with the applicable sections in the following ANSI Standards:

- IEEE C37.20.3 – IEEE Standard for metal-enclosed interrupter switchgear
- IEEE C37.20.4 – IEEE Standard for indoor AC Switches (1kV - 38kV) for use in metal-enclosed switchgear
- ANSI C37.22 – Preferred Ratings and Related Capabilities for Indoor AC Medium-Voltage Switches Used in Metal-Enclosed Switchgear
- IEEE C37.30 – Requirements for High-Voltage Air Switches
- ANSI C37.72 – High-Voltage Switches, Bus Supports, and Accessories – Schedules of Preferred Ratings, Construction Guidelines, and Specifications
- ANSI C37.34 – Test Code for High-Voltage Air Switches
- ANSI C37.57 – Metal-Enclosed Interrupter Switchgear Assemblies – Conformance Testing
- ANSI C37.58 – Indoor AC Medium-Voltage Switches for use in Metal-Enclosed Switchgear – Conformance Test Procedures

Dimensions for Federal Pacific Metal-Enclosed Switchgear ①

Voltage Class	Type of O.C. Protection	Width (in inches)		Height ② (in Inches)	Depth ③ (in Inches)
		Manual	Motor Operated		
5kV	Current Limiting ③	36	46	90	46
	Draw-out VCB	36	—	90	94
	Expulsion Fuse	41	46	90	46
15kV	Current Limiting ③	36	46	90	46
	Draw-out VCB	36	—	90	94
	Expulsion Fuse	41	46	90	46
25kV	Current Limiting ③	—	—	—	—
	Draw-out VCB	48	53	120	48
35kV	Current Limiting ③	—	—	—	—
	Draw-out VCB	60	—	130	60

Notes for Dimensions Table:

- ① Dimensions are for standard production products.
- ② Add 5 inches to the height for Outdoor NEMA 3R
- ③ G&W Commutating Current-Limiting fuses are available for all voltages 5-38kV. Contact factory for dimensions.
- ④ If Rear-Entry Compartment is needed, increase the depth of the compartment by the following dimensions:
 5kV-add 16 inches
 15kV-add 16 inches
 25 kV-add 24 inches
 35kV-add 30 inches

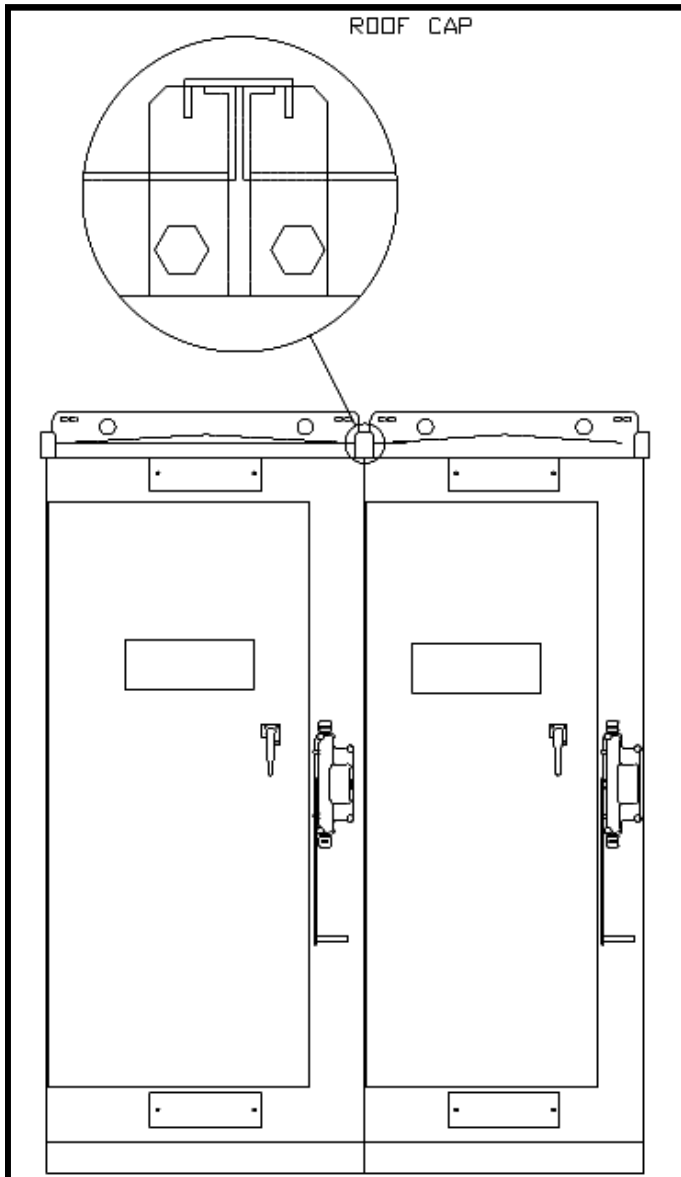

Figure 8. Outdoor Roof Construction with gasket between roof and enclosure flanges.

Circuit Protection Devices Available From Federal Pacific

Power Fuses Ratings - Expulsion Type

Nom. Voltage in kV	Max. Cont. Amps.	Expulsion Fuse Type	Manufacturer	Circuit Max. Available Fault-Current in Amps Sym.	Max. Fault-Current in Amps Asym.	Three-Phase MVA Sym.
4.16	200	DBU	Cutler-Hammer	22,400	14,000	200
4.16	200	RBA-200	Cutler-Hammer	19,000	30,000	237
4.16	200	SM-4	S&C	17,200	27,500	125
4.16	200	SM-5	S&C	37,500	60,000	200
4.16	400	RBA-400	Cutler-Hammer	37,500	60,000	270
14.4	200	DBU	Cutler-Hammer	14,000	22,400	350
14.4	200	RBA-200	Cutler-Hammer	14,400	23,000	350
14.4	200	SM-4	S&C	12,000	20,000	310
14.4	200	SMU-20	S&C	14,000	22,400	350
14.4	400	RBA-400	Cutler-Hammer	29,400	47,000	730
14.4	400	SM-5	S&C	25,000	40,000	620
24.9	200	DBU	Cutler-Hammer	12,500	20,000	500
24.9	200	RBA-200	Cutler-Hammer	6,900	11,100	410
24.9	200	SM-4	S&C	9,400	15,000	410
24.9	200	SMU-20	S&C	12,500	20,000	540
24.9	400	RBA-400	Cutler-Hammer	21,000	33,500	840
24.9	400	SM-5	S&C	20,000	32,000	860
34.5	200	DBU	Cutler-Hammer	10,000	16,000	800
34.5	200	RBA-200	Cutler-Hammer	6,900	11,100	410
34.5	200	SM-4	S&C	6,250	10,000	370
34.5	200	SMU-20	S&C	8,450	13,500	500
34.5	400	RBA-400	Cutler-Hammer	16,800	26,800	1,000
34.5	400	SM-5	S&C	17,500	28,000	1,045

Drawout Vacuum Circuit Breaker

Nominal Voltage in kV	Max. Cont. Amps	Manufacturer	Circuit Max. Available Fault-Current in Amps. Sym.	Max. Fault-Current in Amps Asym. (1.6x sym.)	Three-Phase MVA Sym.
14.4	2000	Cutler-Hammer Mini-Vac	40,000	64,000	500
14.4	1200	Siemens GMI	23,000	37,000	500



Cutler-Hammer MiniVac® Circuit-Breaker module with integral CTs and Relay

Power Fuse Ratings - Current Limiting

Nom. Voltage in kV	Max. Cont. Amps.	Current-Limiting Fuse Type	Manufacturer	Circuit Max. Available Fault-Current in Amps Sym.	Peak Let-Thru Current in Amps on Max. Available Fault-Current Circuit	Three-Phase MVA Sym.
4.16	450	CLE/HLE ①	Cutler-Hammer	63,000	47,000	450
4.16	450	EJO-1	General Electric	50,000	40,000	350
4.16	600	CL-14	Ferraz-Shawmut	63,000	—	450
4.16	600	PAF ②	G&W	40,000	20,000	275
4.16	750	CLE	Cutler-Hammer	40,000	75,000	275
4.16	900	BOLT-AZ055B1DARO	Ferraz-Shawmut	63,000	—	450
4.16	900	EJO-1	General Electric	50,000	80,000	360
4.16	1100	151D870G01	Cutler-Hammer	70,000	85,000	640
4.16	1350	141D870G02	Cutler-Hammer	90,000	85,000	650
14.4	200	CS-3	Ferraz-Shawmut	50,000	14,000	1350
14.4	200	EJO-1	General Electric	50,000	30,000	1350
14.4	600	CL-14	Ferraz-Shawmut	50,000	15,000	1350
14.4	300	CLE/HLE ①	Cutler-Hammer	63,000	35,000	1500
14.4	300	EJO-1	General Electric	50,000	37,000	1342
14.4	600	PAF ②	G&W	60,000	60,000	1492
24.9	600	PAF ②	G&W	40,000	40,000	1700
34.5	600	PAF ②	G&W	40,000	40,000	22400

① Includes CLE, HLE, BHLE, and HCL medium voltage current-limiting fuses.

② PAF® is a commutating current-limiting fuse, per ANSI C37.48.1, suitable for higher current applications, through 630A.