

WALL-MOUNTED FUSE CABINETS

15kV • 25kV



Indoor/Outdoor

Federal Pacific Metal-Enclosed Wall-Mounted Fuse Cabinets provide a safe, convenient method of fusing loads where switching is not required or is done elsewhere. These space-efficient cabinets may be wall or floor mounted and may be located in dry indoor vaults or outdoors. Typical applications include protection of:

- A transformer in an industrial or commercial building.
- A high-density load in a commercial building.
- A feeder circuit fed by a selector switch, manual or automatic.

Wall-mounted fuse cabinets are available for three-phase applications on 15 kV and 25 kV systems.

Indoor/outdoor design: All welded, 11-gauge steel with gasketed doors (on outdoor units), three-point door latches, screened rain-proof louvers and padlockable handle. The anti-corrosion finish

system includes chemical cleaning, phosphatizing (or zirconization) and sealing followed by an electrostatically deposited powder epoxy primer. The finish coat is an electrostatically deposited polyester topcoat. The finish system meets the requirements of ANSI C57.12.28 and the standard color is ANSI 61 light gray.

Cable Termination Options:

- Knockouts for conduit.
- Porcelain flange mounted potheads.
- 200-ampere bushing wells for loadbreak inserts and elbows, 15kV, 95kV BIL and 25kV, 125kV BIL.
- 600-ampere bushings for non-loadbreak type separable connectors 15kV, 95kV BIL and 25kV, 125kV BIL.

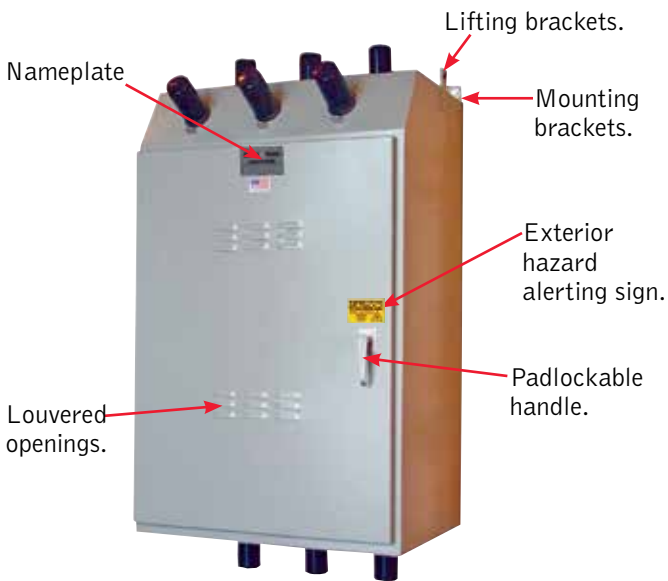

Exterior of Wall-Mounted Fuse Cabinet.

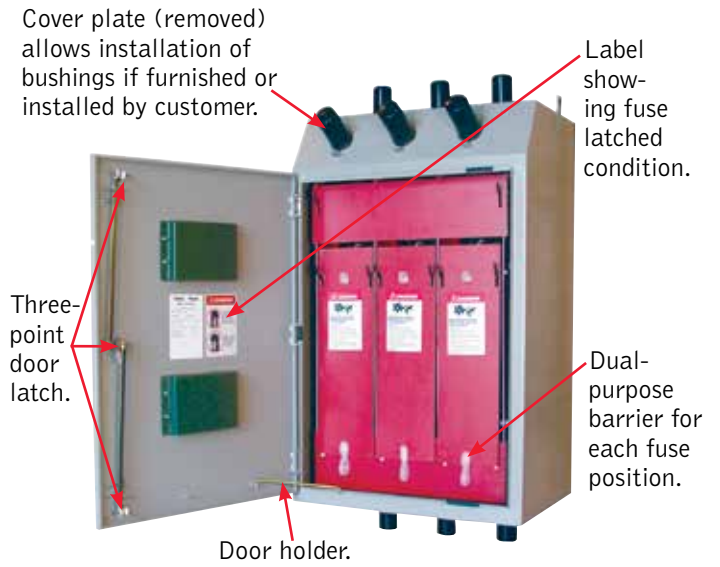

Wall-Mounted Fuse with door open to show optional internal dual-purpose barrier system.

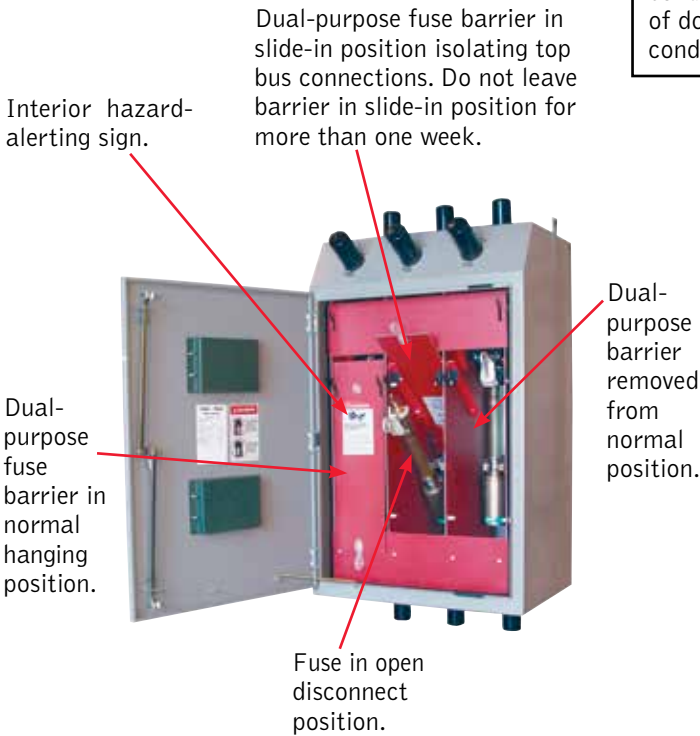
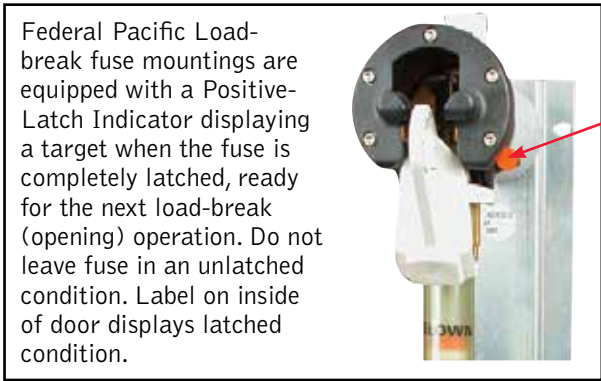

View Showing Various Positions for Optional Dual-Purpose Fuse Barriers. (Shown with SML-4Z fuseholders)

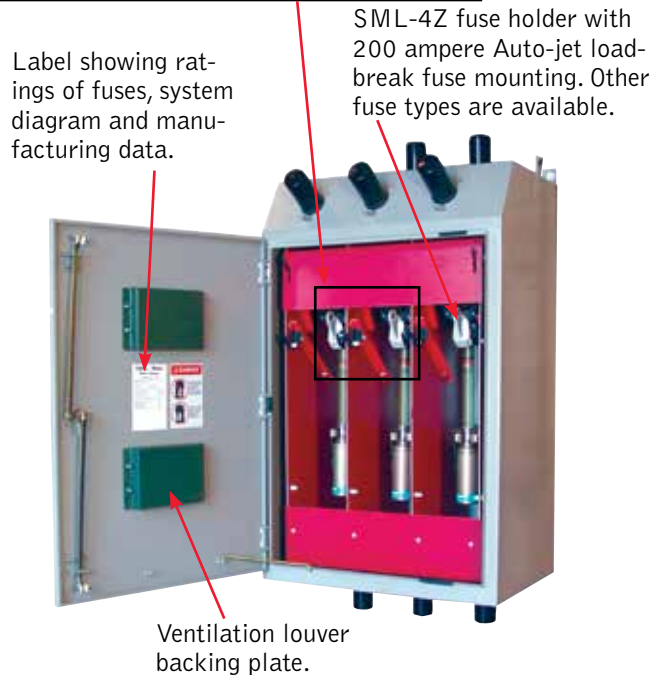

View With Door Open and Barriers Removed. (Shown with SML-4Z fuseholders)

INDOOR/OUTDOOR SPECIFICATIONS

(Illustrated with optional porcelain terminators)

Section View Loop Feed with Non-Loadbreak Fuse

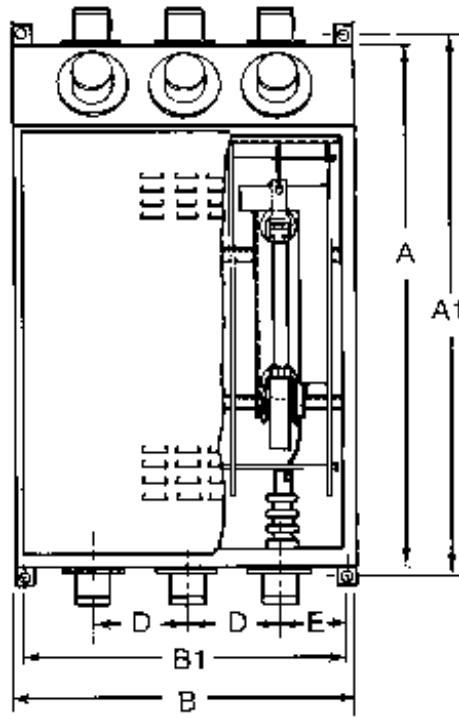
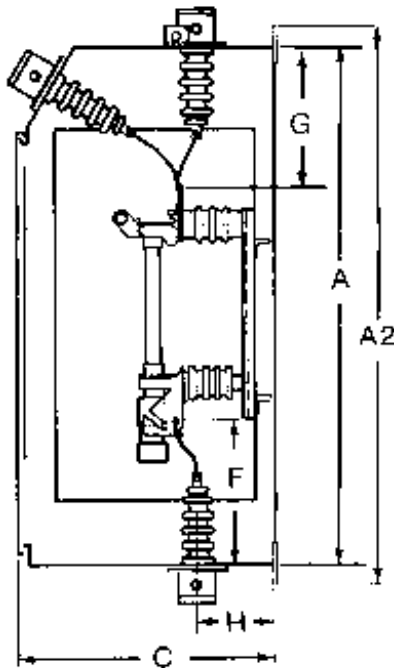

Section View Loop Feed with Non-Loadbreak Fuse

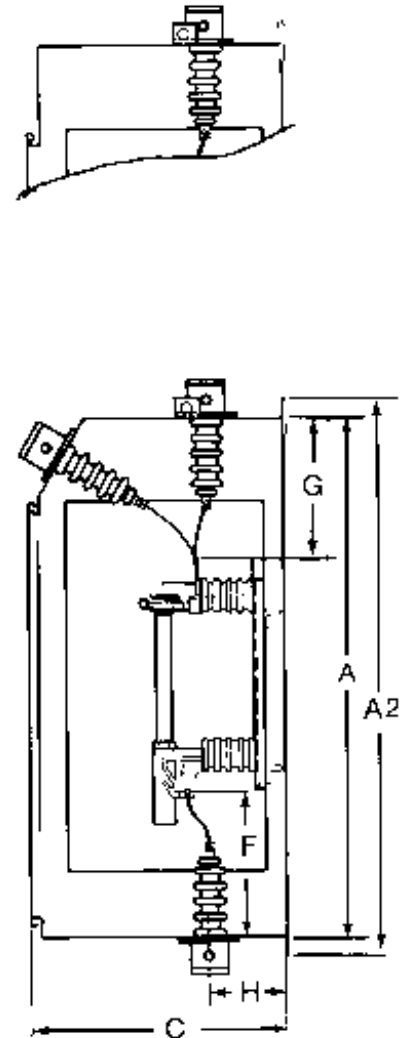

Wall-Mounted Cabinets

Catalog Number	Ratings				Fuse Unit or Refill Type	Dimensions - Inches†									
	Nom.	Max. Des.	BIL	Amps		A	A1	A2	B	B1	C	D	E	F	G
*WMF-315-63	13.8	17.0	95	200E	SM-4	48	51	53	35	32-1/2	26	9-3/4	8-1/2	12-5/16	9-9/16
*WMF-315-93	13.8	17.0	95	200E	SM-4	56-1/2	59-1/2	61-1/2	35	32-1/2	26	9-3/4	8-1/2	15-9/16	8
*WMF-325-63	25	27	125	200E	SM-4	60	63	65	44	41-1/2	33	12	10	16-1/4	10
*WMF-325-94	25	27	125	200E	SM-4	66	60	71	44	41-1/2	33	12	10	19-1/4	10
**WMF-315-63-L4Z	13.8	17.0	95	200E	SM-4	48	51	53	35	32-1/2	26	9-3/4	48-1/2	12-5/16	9-9/16
**WMF-315-93-L4Z	13.8	17.0	95	200E	SM-4	56-1/2	9-1/2	61-1/2	35	32-1/2	26	9-3/4	8-1/2	15-9/16	8
**WMF-325-63-L4Z	25	27	125	200E	SM-4	60	63	65	44	41-1/2	33	12	10	16-1/4	10
**WMF-325-93-L4Z	25	27	125	200E	SM-4	66	69	71	44	41-1/2	33	12	10	19-1/4	10
**WMF-315-63-U20	13.8	17.0	95	200E	SM-4	48	51	53	35	32-1/2	26	9-3/4	8-1/2	12-5/16	9-9/16
**WMF-315-93-U20	13.8	17.0	95	200E	SM-4	56-1/2	59-1/2	61-1/2	35	32-1/2	26	9-3/4	8-1/2	15-9/16	8
**WMF-325-63-U20	25	27	125	200E	SMU-20	60	63	65	44	41-1/2	33	12	10	16-1/4	10
**WMF325-93-U20	25	27	125	200E	SMU-20	60	69	71	44	41-1/2	33	12	10	16-1/4	10

† Dimensions are not to be used for construction purposes.

* These are non-loadbreak units designed to accept the type SM-4 fuseholder.

** The Auto-jet loadbreak integral interrupter is included in these units, accepting either the SML-4Z fuseholder, the SMU-20 fuse with SML-20 end fittings, or DBU fuses and end fittings. The Auto-jet device permits live switching up to 200 amperes with an ordinary hotstick.

WALL-MOUNTED SWITCH CABINETS

15kV • 25kV



Figure 1, Indoor/Outdoor Switch Cabinet

The Federal Pacific Wall-Mounted Switch Cabinets include the Federal Pacific Auto-Jet®II Load-Interrupter Switch in a space efficient, all-welded, Indoor/Outdoor 11-gauge steel enclosure designed for wall or floor mounting (with optional floor stand). Mounting tabs are included on the back at the top and bottom. Lifting eyes are provided on the sides at the top. Holes with removable plates are provided in the top and bottom for conduit entrance.

The enclosure door is secured at three points - two pentahead bolts and a padlockable tab - and has stainless-steel hinges and pins. A three-point latching design with a lockable handle is also available.

A window barrier is provided in the interior to allow viewing the position of the switch blades when optional dual-purpose barriers are in the normal hanging position. Louvers are installed in the door to ensure proper ventilation. The door opening is gasketed at top and on both sides for outdoor applications.

The anti-corrosion finish system includes chemical cleaning, phosphatizing, followed by a powder epoxy primer. The finish coat is an oven-baked, powder polyester finish. Standard color is ANSI 61, light gray.

The Auto-Jet® II Load-Interrupter Switch used in Federal Pacific Wall-Mounted Switch Cabinet is rated 600 amperes, 15 kV, is UL® Recognized and features an industry-leading, 3-time duty-cycle fault closing rating of 40,000 amperes asymmetrical.

Typical applications include:

- Service Entrance Switching
- Transformer Primary and Secondary Switching
- Line Switching
- Load Switching
- Loop Switching

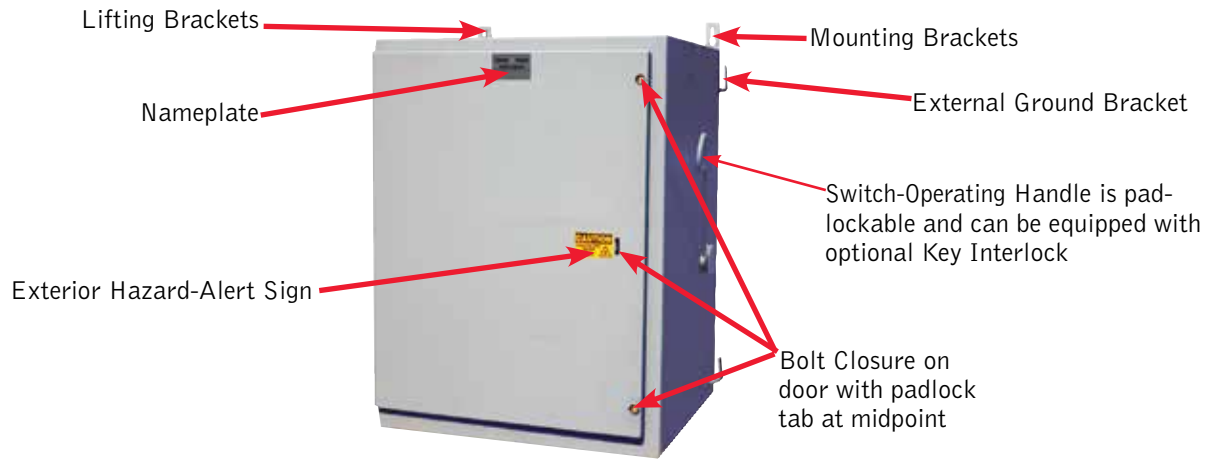

Exterior view of rugged Federal Pacific Wall-Mounted Switch Enclosure.

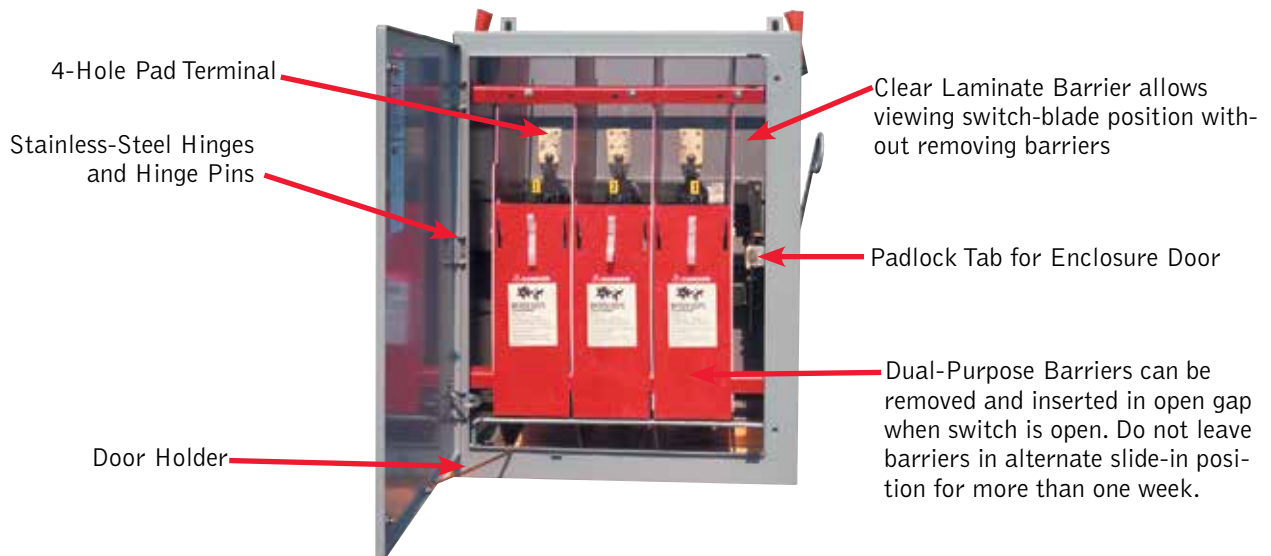

Interior view of wall-mounted switch to show barrier arrangement.

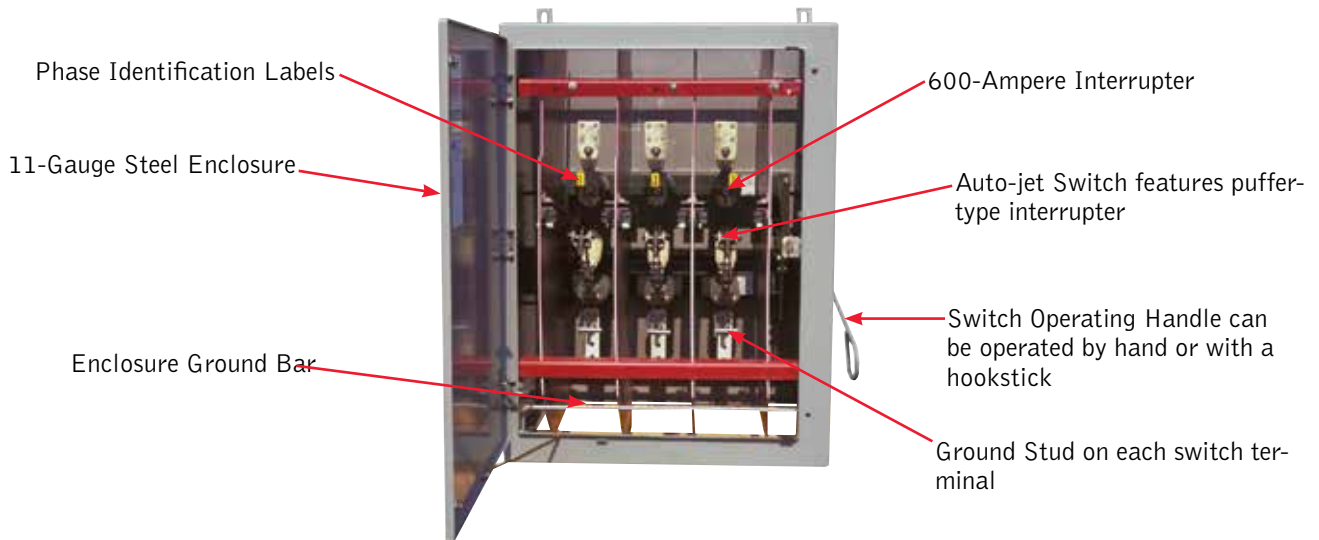

Interior view of wall-mounted switch to show Auto-jet® II switch.