

TYPE PMDF

INSTRUCTIONS FOR INSTALLATION AND OPERATION

15kV • 25kV • 35kV

QUALIFIED PERSONS	1
SAFETY	2
Safety Information	2
Following Safety Instructions	2
Safety Precaution	2
INTRODUCTION	3
Receiving	3
Handling	3
Storage	3
GENERAL DESCRIPTION	3
SECURITY FEATURES	3
INSTALLATION	4
Placement of Unit	4
Customer Cable Connections	4
BUSHING WELLS AND BUSHINGS	5
Bushing Wells	5
Bushings	6
REMOVAL OF LOADBREAK ELBOWS	6
INSTALLATION OF METERING TRANSFORMERS	7
TYPICAL DIMENSIONS	8
DOOR SYSTEM	9
Door-Latch Features	9
MAINTENANCE	10
OPTIONAL FEATURES	10



Figure 1. External views of PMDF Pad-Mounted Switchgear with optional KWH meter mounted in an isolated low-voltage compartment attached to unit. Federal Pacific PMDF models meet applicable industry standards, which are ANSI 386 and IEEE C57.12.28.

Qualified Persons

⚠ WARNING

The equipment covered by this publication must be selected for a specific application and it must be operated and maintained by **Qualified Persons** who are thoroughly trained and knowledgeable in the installation, operation, and maintenance of underground power distribution equipment along with the associated hazards that may be involved. This publication is written only for such qualified persons and is not intended to be a substitute for adequate training and experience in safety procedures for this type of equipment. Proper installation is the responsibility of the operating and construction personnel and the utility performing and authorizing the work. Completion of these instructions implies no further warranty by the manufacturer.

A **Qualified Person** is defined in the National Electrical Code (NEC/NFPA-70) as:

One who has skills and knowledge related to the construction and operation of the electrical equipment and installations and has received safety training to recognize and avoid the hazards involved.

The specific electrical safety training requirements to be considered a qualified person are detailed in **NFPA-70E, Article 110.1(D), Employee Training**. Some of the requirements from the 2012 edition are shown below. For the specific detailed training requirements for a Qualified Person make certain to refer to the most recent applicable edition.

These training requirements would include, but are not limited, to the following key points:

- The skills and techniques necessary to distinguish exposed energized parts from other parts of electrical equipment.
- The skills and techniques necessary to determine the proper approach distances corresponding to the voltages to which the qualified person will be exposed.
- The proper use of the special precautionary techniques, personal protective equipment, insulating and shielding materials, and insulated tools for working on or near exposed energized parts of electrical equipment.
- Tasks performed less often than once per year have additional training requirements.

These instructions are intended only for such qualified persons. They are not intended to be a substitute for adequate training and experience in safety procedures for this type of equipment. Additionally, the recommendations in this instruction bulletin are not intended to supersede or to take the place of established utility safety guidelines and established practices. If there is any question, consult with your foreman or supervisor, as appropriate.

Please refer to OSHA 29 CFR 1910.399 and NFPA 70E Articles 100 and 110.

SAFETY INFORMATION

Understanding Safety-Alert Messages

There are several types of safety-alert messages which may appear throughout this instruction bulletin as well as on labels attached to the pad-mounted switchgear. Familiarize yourself with these types of messages and the importance of the various signal words, as explained below.

DANGER

DANGER indicates a hazardous situation which, if not avoided, will result in death or serious injury.

WARNING

WARNING indicates a hazardous situation which, if not avoided, could result in death or serious injury.

CAUTION

CAUTION indicates a hazardous situation which, if not avoided, could result in minor or moderate injury.

NOTICE

NOTICE is used to address practices not related to physical injury.

SAFETY INSTRUCTIONS

Safety Instructions (or equivalent) signs indicate specific safety-related instructions or procedures.

SAFETY PRECAUTION

DANGER

Federal Pacific Fuse Mountings in conjunction with appropriate fuses are designed to protect equipment and to disconnect faulted equipment from the system. The fuses cannot protect personnel from injury or electrocution if contact is made with energized circuits or hardware.

FOLLOWING SAFETY INSTRUCTIONS

NOTICE



Thoroughly and carefully read this instruction bulletin before installation of the pad-mounted switchgear, before switching with elbows or installing or accessing the metering transformers in this equipment, and before performing any maintenance on the equipment.

If you do not understand any portion of this instruction bulletin and need assistance, contact the Switchgear Division of Federal Pacific at 276-466-8200.

Replacement Instructions & Labels

If you need additional copies of this instruction bulletin, contact Federal Pacific at 276-466-8200.

It is important that any missing, damaged, or faded labels on the equipment be replaced immediately. Replacement labels are available by contacting Federal Pacific.

Introduction

PMDF pad-mounted switchgear is designed to provide dependable on-the-line service and to make installation, operation and maintenance as simple as possible. Federal Pacific PMDF models meet applicable industry standards, which are ANSI 386 and IEEE C57.12.28.

High quality materials and careful workmanship have been combined to provide the best switchgear available. The switchgear has been thoroughly inspected and adjusted at the factory. However, successful operation depends on proper installation and care.

This manual has been written to assist you in obtaining long and economical service from your switchgear.

Read this manual before installing and operating your switchgear.

Receiving

Upon receipt of the switchgear, check each item received for shipping damage. Each item should be checked against the shipping manifest to assure that the proper number of items were received. Should any shortage or damage exist, note it on the shipping papers. A claim should be filed at once with the carrier and the Federal Pacific agent or sales office should be notified.

NOTICE

The carrier is responsible for all damage occurring during transit. Receiving personnel must note all damage to equipment on shipping papers so that claims can be processed.

Handling

Removable lifting plates are provided to allow the use of hooks to lift the complete enclosure. The lifting device should be arranged to evenly distribute the lifting force between the lifting plates.

CAUTION

Do not lift at an angle less than 60° from the horizontal. See Figure 2. A spreader bar may be required to maintain the proper minimum angles. Failure to comply with this requirement may result in damage to the equipment.

The switchgear is securely mounted to a sturdy shipping pallet with provisions for forklift use. The use of a forklift truck is not recommended, but if this method is used the forks must extend completely through the skid to avoid damaging the equipment.

Storage

The switchgear as received may be wrapped in a protective plastic film, which must be removed for storage.

NOTICE

To avoid damage to the enclosure finish, the protective film must be removed for outdoor storage of unit.

Export or special packing is available as an option based on customer's requirements and special conditions. Separate instructions are available for these situations.

General Description

PMDF dead-front pad-mounted switchgear consists of one or more single-pole 200 ampere bushing wells to accommodate 200 ampere load-break (or non-loadbreak) inserts and elbows. Alternately, the unit may be optionally equipped with 600 ampere bushings to accommodate 600 ampere elbow connectors. When used with 200 ampere bushing wells and loadbreak inserts and elbows, and other protective devices, the PMDF switchgear provides a secure and efficient means of single-pole switching with elbows on the incoming lines.

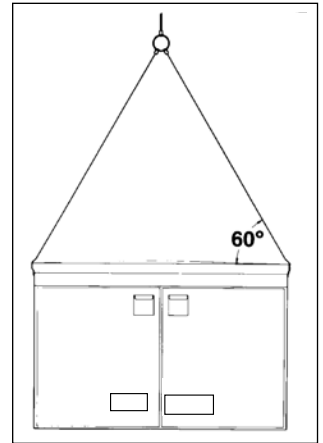

Figure 2. Lifting Method

In addition, the unit may be furnished with metering transformers (voltage transformers and current transformers), or provisions only for metering transformers, and with optional meter socket (mounted on the enclosure or in a low-voltage compartment) and associated wiring. When the unit is provided with "Mounting Provisions only for Metering Transformers, the customer is responsible for providing, installing, wiring and connecting all metering transformer and associated secondary components.

Security Features

PMDF pad-mounted switchgear meets the security requirements in IEEE C57.12.28 and incorporates a number of security features to minimize hazards to operating personnel.

1. Rugged 11-gauge steel, using all welded construction of the enclosure, with a bolted roof, and hinged and bolted doors assures a tamper-resistant design.
2. Padlockable doors with security bolts provide customer-controlled access.
3. 200 ampere bushing wells of cycloaliphatic epoxy and with removable studs.

WARNING

Before energizing the switchgear, remove all yellow and red shipping caps on bushings and bushing wells, and replace them with a suitable system of insulated separable connectors (elbows), insulating protective covers, or plugs, as appropriate.

Failure to replace the shipping caps may result in flashover, equipment damage, serious personal injury, or death.

4. Hazard-alert signs and labels, both external and internal, indicate potential hazards to personnel.
5. Full-width fiberglass barriers (or optional clear polycarbonate barriers) behind doors on fuse compartment.
6. Wind brace to secure enclosure door open and a cable-connected clip to secure inner barriers open.

Installation

Each unit is shipped with this instruction bulletin which is located inside one of the compartment doors. These instructions should be reviewed prior to placing unit on pad.

Placement of Unit

Remove unit from shipping pallet per handling procedures on Page 3 (see Figure 2). When unit has been correctly oriented and placed on pad (see Figure 3), verify that unit is level and shim if necessary between unit base and pad. Secure unit to pad using four (4) tie-down clips as furnished (see Figures 3, 4 and 5). Check compartment door operation for any binding due to enclosure distortion and re-shim if necessary. A recessed grouting should then be applied between unit base and pad to prevent entry of foreign objects, vegetation, insects, animals, and moisture.

Customer Cable Connections

1. Make up the primary cable connections per user's standard URD operating procedures, cable manufacturer instructions, and elbow terminator manufacturer instructions.

⚠ WARNING

Before energizing the switchgear, remove all yellow and red shipping caps on bushings and bushing wells, and replace them with a suitable system of insulated separable connectors (elbows), insulating protective covers, or plugs, as appropriate.

Failure to replace the shipping caps may result in flashover, equipment damage, serious personal injury, or death.

2. Connect the concentric neutral wires to the enclosure ground pads inside the enclosure to facilitate ground system conforming to user's grounding procedures.

⚠ WARNING

The maximum momentary rating of the switchgear must be considered when selecting cable size for connecting switchgear to system ground. Refer to unit rating sheet on inside of doors.

3. Install fault indicators, if applicable in accordance with the manufacturer's instructions.

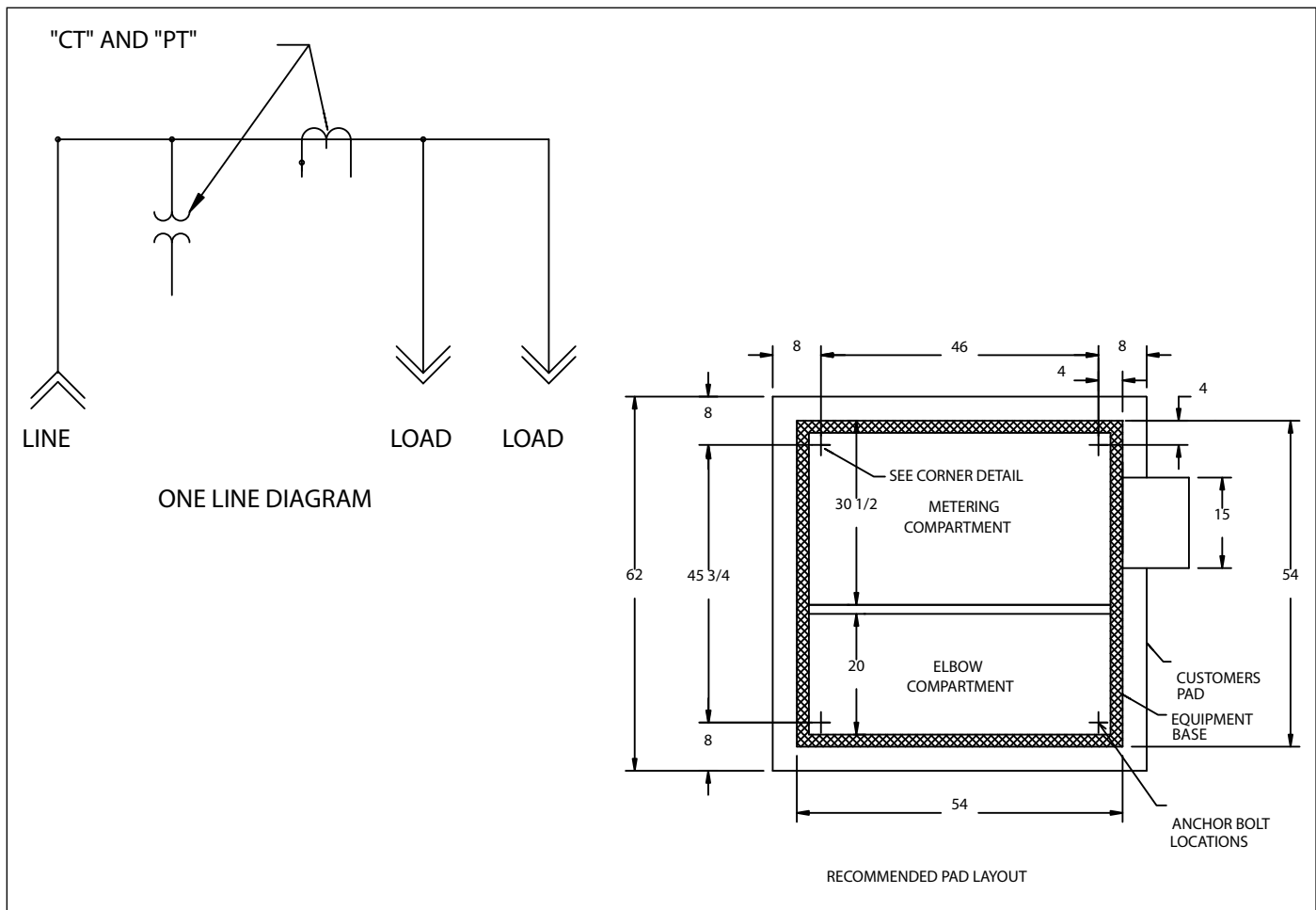

Figure 3. Typical pad layout and associated circuit diagram for one particular PMDF design. DO NOT USE FOR CONSTRUCTION PURPOSES.

Bushing Wells and Bushings

Federal Pacific PMDF Pad-Mounted Switchgear is furnished with a choice of either 200 ampere bushing wells or 600 ampere bushings on the line side or load side. The bushing wells and bushings meet ANSI 386 standard requirements.

Bushing Wells

The 200 ampere bushing wells accommodate 200 ampere elbow (separable insulated) load-break connectors and accessories. The units are shipped with a yellow dust cover over each bushing well to prevent contamination. Dust covers are NOT capable of providing any electrical insulation at medium voltage levels. Therefore, if an elbow is not to be connected to a bushing well, prior to energization the dust cover **MUST** be removed and replaced with an insulating protective bushing-well plug. See Figure 6.

WARNING

For all un-terminated phase positions, failure to remove dust covers and replace with a protective insulating bushing-well plug prior to energization may result in equipment damage, personal injury or death.

Install load break inserts following the insert manufacturer's instructions supplied therewith. Terminate cables and install 200 ampere load-break elbows and accessories following instructions provided by the cable manufacturer and the elbow manufacturer. The 200 ampere elbows are a load-break device and, if standard system operating practices and conditions permit, may be removed when the equipment is energized, providing single-pole load-break live switching is performed using insulated shotgun clamp sticks. Before performing any live-switching with elbows, install insulating feed-through standoff bushings on the parking stand adjacent to the load-break elbow to be switched.

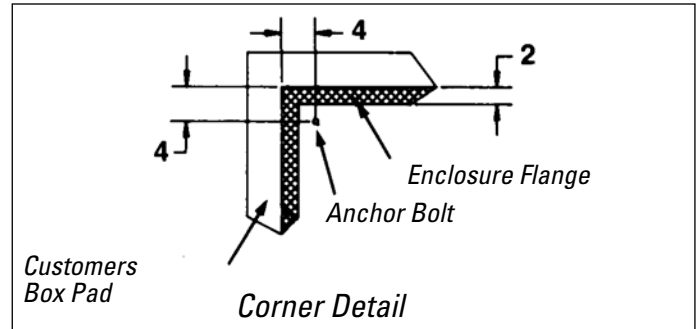

Figure 4. Typical Anchor Bolt Location

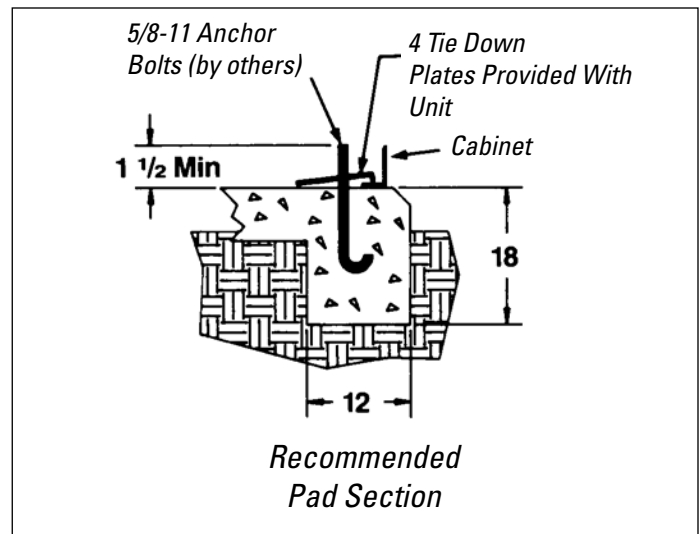

Figure 5. Bolting Units to Pad



Figure 6. View of PMDF elbow-compartment side with doors open to show customer selected bushing wells (pictured) or, if specified optional 600 ampere bushings. The 200 ampere bushing wells accommodate load-break inserts and elbow connectors. Dust covers (yellow discs) must be removed from all unused positions and replaced with protective insulating bushing-well plugs (or insulating bushing covers when furnished with 600 ampere bushings, which have red dust covers).

DANGER

When removing energized 200 ampere elbows (separable insulated) connectors, do not allow the elbow probe to touch any grounded surface. Before working on any cables or circuits, test for voltage and ground the circuit. Failure to follow proper procedures while the equipment is energized will result in equipment damage, personal injury or death.

Always follow user's and manufacturer's standard operating procedures when installing, maintaining or removing 200 ampere load-break elbow connectors and accessories. Such procedures should always include:

1. Verifying the correct circuit is being maneuvered,
2. Installing portable feed-through standoff bushings on the parking stand adjacent to the load-break elbow to be switched,
3. Recognizing that the unit may be subject to back feed and taking necessary precautions to isolate the equipment from such possibility before maneuvering 200 amp elbows when dead-break procedures are to be followed,
4. Testing for voltage, and
5. Grounding the circuits before any other work is attempted.

Bushings

The 600 ampere bushings accommodate 600 ampere elbow (separable insulated) connectors and accessories. The units are shipped with a red dust cover over each bushing to prevent contamination. Dust covers are NOT capable of providing any electrical insulation at medium voltage levels. Therefore, if an elbow is not to be connected to a bushing, prior to energization the dust cover MUST be removed and replaced with an insulating protective bushing cover.

WARNING

Failure to remove dust covers and replace with a protective insulating bushing cover prior to energization may result in equipment damage, personal injury or death.

Terminate cables and install 600 ampere elbows and accessories following instructions provided by the cable manufacturer and the elbow manufacturer. The 600 ampere elbows are a dead-break device and must NOT be removed when the equipment is energized.

DANGER

Do not attempt to remove 600 ampere elbows (separable insulated) connectors when the equipment is energized. Any attempt to remove 600 ampere elbows while the equipment is energized will result in equipment damage, personal injury or death.

Always follow user's and manufacturer's standard operating procedures when installing, maintaining or removing 600 ampere elbow connectors. Such procedures should always include:

1. Opening adjacent load-interrupting devices to completely de-energize the unit,
2. Recognizing that the unit may be subject to back feed and taking necessary precautions to isolate the equipment from such possibility before maneuvering 600 amp elbows,
3. Testing for voltage to verify circuit is de-energized before maneuvering 600 amp elbows, and
4. Grounding the circuits before any other work is attempted.

Removal of Load-Break Elbows

1. Remove the padlock and fully loosen the penta-head bolt. Pull and lower the door handle cover to open the active elbow-compartment door and secure with the windbrace. See Figures 7 through 14.
2. Loosen the two pentahead bolts that secure the passive elbow compartment door and secure it open using the windbrace.
3. System operating practices may allow load-break elbows to be switched while the associated cable is energized. Follow load-break elbow manufacturer's procedures for proper technique when live switching is to be performed using the elbows. If live switching is not permitted with elbows, appropriately rated voltage testers should be used to verify that the circuit is completely de-energized.
4. Using the shotgun clamp stick, install and secure the feed-through standoff bushing on the parking stand.
5. If live switching of elbows is not permitted for operating circumstances of the system, test the elbow to be moved for voltage. After verifying that voltage is not present, or if live switching is permitted, use the shotgun clamp stick to remove the elbow connector from the appropriate bushing well, following standard system operating procedures and the elbow manufacturer's instructions. Move the elbow connector onto a standard feed-thru standoff bushing that is placed in the parking stand.

DANGER

When removing energized 200 ampere elbows (separable insulated) connectors, do not allow the elbow probe to touch any grounded surface. Before working on any cables or circuits, test for voltage and ground the circuit. Failure to follow proper procedures while the equipment is energized will result in equipment damage, personal injury or death.

6. Install an insulating protective cover on the exposed 200 amp bushing-well insert following grounding-elbow manufacturer's instructions. Connect the ground-clamp connector of the grounding elbows to the enclosure ground rod.

⚠ WARNING

Before installing grounding elbows, test for voltage. Failure to properly test for voltage to establish that the circuit is de-energized before installing grounding elbow may result in equipment damage, personal injury or death.

7. If appropriate for operating circumstances of the system, test the remaining feed-through standoff bushings for voltage and, after confirming that voltage is not present, then install a grounding elbow on the remaining bushing.
8. Repeat the above procedures for each 200 ampere load-break elbow that is to be moved.
9. After completing the work to be performed, the ground elbows are to be removed. First, remove the grounding elbow from the feed-thru bushing. Then, remove the ground connector from the ground rod.
10. If applicable, remove the insulating protective cover from the bushing-well insert.
11. Following elbow manufacturer's proper procedure for positioning, removal and closing circuit using elbows, move the elbow connector from the feed-through standoff bushing and secure it onto the 200 ampere bushing-well insert.
12. Remove the feed-through standoff bushing.
13. Remove and store the windbrace.
14. Close and secure the passive door by fully tightening both the top and bottom penta-head bolts.
15. Close and padlock the main doors before leaving the gear.

Installation of Metering Transformers

1. Remove the padlock and fully loosen the penta-head bolt. Pull and lower the door handle cover to open the active elbow-compartment door and secure with the windbrace. See Figures 7 through 14.
2. Loosen the two pentahead bolts that secure the passive elbow compartment door and secure it open using the windbrace.
3. Loosen the penta-head bolts on each inner barrier and secure them open using the pin proved on the door inserted into the clip on the top edge of the barrier.
4. Install the voltage transformers (also known as potential transformers or PTs) and current transformers (CTs) in accordance with the manufacturer's instructions and the user's standard operating practice. Make certain that the current transformers are installed and oriented in the proper polarity.
5. The voltage transformer incoming connections must be installed on the line (or source) side of the current transformer connections.
6. Make the connections for the voltage transformers with appropriately sized copper bus or insulated copper cable.
7. Make the connections for the wound (or bar) type current transformers with the appropriately sized copper bus or copper cable.
8. Install and wire a shorting-type terminal block on the secondary side of the current transformers in accordance with applicable manufacturer's instructions and user's standard practice instructions.
9. Install and wire a terminal block on the secondary side of the voltage transformer in accordance with the applicable manufacturer's instructions and the user's standard practice instructions.
10. Make appropriately protected secondary connections from the voltage transformer's and current transformers to the kilowatt-hour meter in accordance with the applicable manufacturer's instructions and the user's standard practice instructions.

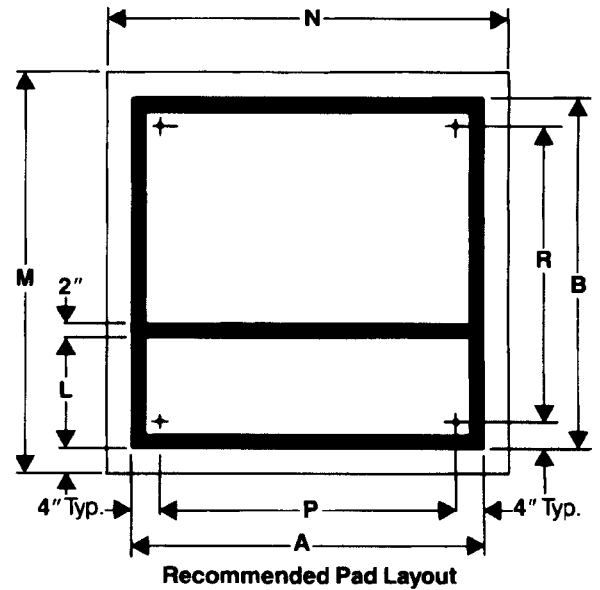
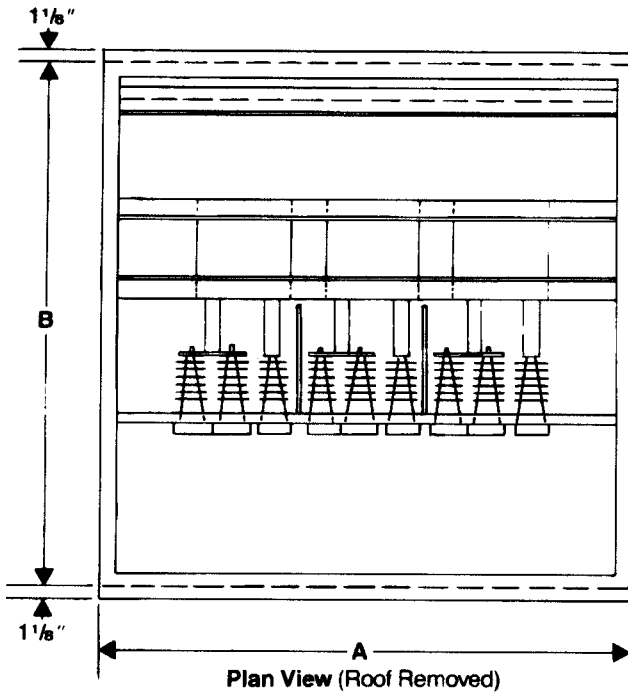
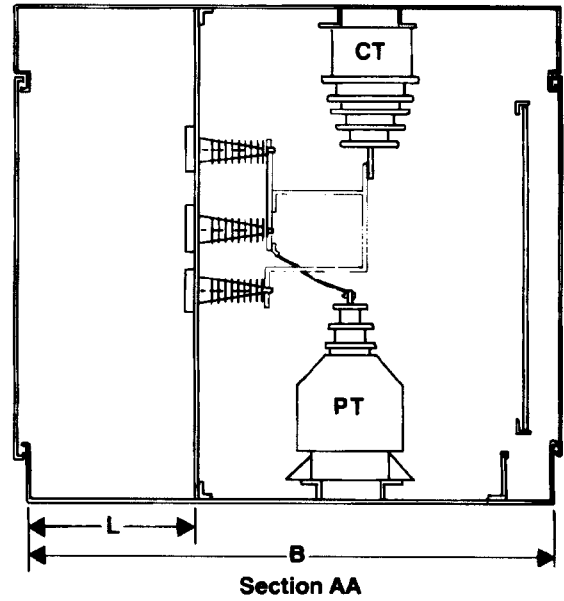
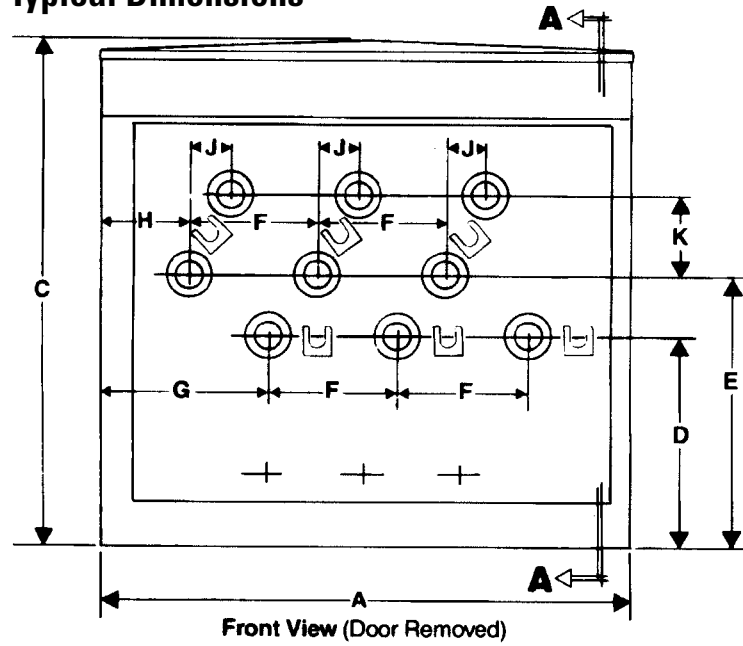

Figure 7. Open door view of PMDF with inner barriers bolted in place.



Figure 8. Open door view of metering transformers with fiberglass inner barriers secured open.

Typical Dimensions*



Catalog Number	Volt Nom.	kV BIL	Dimensions - Inches*														
			A	B	C	D	E	F	G	H	J	K	L	M	N	P	R
PMDF-315-R6-200	15	95	54	54	51	22	28	14	14	7	NA	NA	22	62	62	46	46
PMDF-315-L9-200	15	95	54	54	51	22	28	14	14	7	5	8-5/8	22	62	62	46	46
PMDF-325-R6-200	25	125	66	66	51	24-1/2	30-1/2	17-1/2	16	8-1/2	NA	NA	24	74	74	58	58
PMDF-325-L9-200	25	125	66	66	51	24-1/2	30-1/2	17-1/2	16	8-1/2	6	8-3/8	24	74	74	58	58
PMDF-335-R6-200	35	150	76	66	53	24-1/2	33	22-1/2	18-5/16	12-9/16	5-5/8	8-1/2	24	74	84	68	58

34.5 kV designed to customer specifications.

*Do not use these dimensions for construction purposes.

Door System

The door latching feature furnished on the main doors provides ease in opening and closing of the doors.

Door-Latch Features

Features of the door-latch system are:

- Three-point latching of doors. See Figure 12.
- After unlatching on opening, the door is secured open with a windbrace. Hinged inner barriers are secured open with a cable-connected pin on the door and inserted into a clip on the top edge of the barrier. See Figure 12. For closing, the door is manually latched, bolted closed and padlocked.
- Unlatching is only accomplished by first rotating (in counter-clockwise direction) the captive penta-head (or hex-head) bolt through several revolutions and then lowering the door handle. See Figures 8 through 10.
- The door padlocking provision prevents unlatching the door-latch cover until the padlock has been removed. Padlocking also secures the door to the cabinet enclosure. See Figures 13 and 14.
- The protective door-latch cover is stainless steel. Also, access to the penta-head bolt is only possible after the padlock has been removed.
- A closed, latched and padlocked door can successfully withstand a "pull" greater than 600 pounds at any point on the door.



Figure 9. Door handle is stainless steel.



Figure 10. Door handle cover is secured closed by a penta-head (or hex-head) bolt. Turn socket counter-clockwise to loosen bolt.



Figure 11. With penta-head bolt fully loosened, handle can be pivoted down to unlatch the door.



Figure 12. Three-point door latch mechanism. Enclosure door is secured open by windbrace. Inner barrier is secured open by a pin on the door inserted into a clip on the barrier.



Figure 13. Padlock cannot be inserted until penta-head bolt is fully tightened.



Figure 14. Always close, latch and padlock the enclosure door before leaving the unit or when working on the opposite side.

Maintenance

Federal Pacific switchgear does not require routine mechanical or electrical maintenance. However, the following are some recommendations for enhancing continued service of the equipment.

1. Yearly mechanical exercising of the loadbreak elbows is recommended.

WARNING

The switchgear must be completely de-energized from all sources before any attempt is made to enter the metering transformer compartment of the switchgear.

2. Check for cleanliness generally, but particularly for accumulation of any foreign material on insulators, barriers and metering transformers.

NOTICE

Barriers and insulators can be cleaned with a non-alcohol based cleaner that does not leave any residue when dry. Residue must be removed.

Optional Features

Standard options can be supplied that best serve the customer's needs and operating practices. These are listed below with the applicable catalog number suffix.

Base Spacer-Non-compartmented or compartmented suffix beginning with letter "-A" — followed by a number, or "-AS" followed by a number when of stainless steel.

Finish Color and Special Cabinet Material

Fault Indicators

Copper Bus (-C)

Strip Heaters

Stainless Steel (-F4)

600 Ampere Bushings in lieu of 200 ampere bushing wells (-600)



This Page Intentionally Left Blank



This Page Intentionally Left Blank

Every effort is made to ensure that customers receive an up-to-date instruction manual on the use of Federal Pacific products; however, from time to time, modifications to our products may without notice make the information contained herein subject to alteration.

